

TM 9-2990-205-34&P

TECHNICAL MANUAL DIRECT SUPPORT AND GENERAL SUPPORT MAINTENANCE MANUAL

(Including Repair Parts and
Special Tools List)

TURBOSUPERCHARGER MODEL 5HDR

NSN 2950-01-432-0369 [655595-3]

NSN 2950-01-434-3229 [655595-4]

NSN 2950-00-397-3384 [11668377-1]

AND NSN 2950-01-167-1700 [187727]

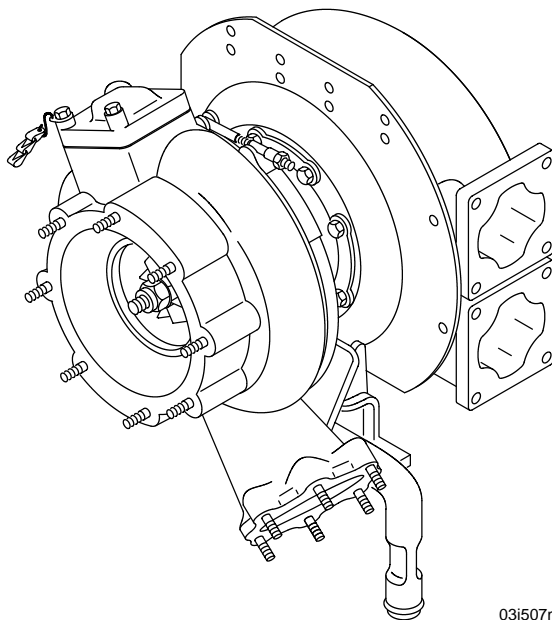

03i507m

Supersedure Notice: This manual supersedes TM 9-2990-205-34&P, dated 21 June 1984, including all changes.
Distribution Statement A: Approved for public release; distribution is unlimited.

HEADQUARTERS, DEPARTMENT OF THE ARMY
30 SEPTEMBER 2005

WARNING SUMMARY



Cleaning solvent is flammable! Use only in well ventilated areas. Keep away from flame, sparks, or heat. Do not smoke while using. Prevent contact with eyes, mouth, and/or skin. Wear rubber gloves when using to prevent skin irritation.



Line pressure for compressed air used for cleaning shall not exceed 30 psi. Wear appropriate eye protection and gloves. Never direct the compressed air stream at another person.

Refer to FM 4-25.11 for first aid instructions.

END ITEM APPLICATION

Turbosuperchargers 655595-3, 655595-4, 11668377-1 and 187727
used on
Engines AVDS-1790-2C, AVDS-1790-2CA, AVDS-1790-2D, AVDS-1790-2DA,
AVDS-1790-2DR, and AVDS-1790-8CR

<u>Vehicles TM No. Series</u>	<u>TM No. Series</u>
Tank, Combat, Full Tracked: 105-MM Gun, M48A5	9-2350-258
Tank, Combat, Full Tracked: 105-MM Gun, M60 and M60A1	9-2350-215
Tank, Combat, Full Tracked: 105-MM Gun, M60A1 (RISE)	9-2350-257
Tank, Combat, Full Tracked: 105-MM Gun, M60A3	9-2350-253
Armored Vehicle Launched Bridge: M48A2 AVLB	5-5420-200
Armored Vehicle Launched Bridge: M60A1 AVLB	5-5420-202
Armored Vehicle Launched Bridge: M48A5 AVLB	5-5420-226
Vehicle, Combat Engineer, Full Tracked: M728	9-2350-222
Recovery Vehicle, Full Tracked: Medium, M88A1	9-2350-256
Recovery Vehicle, Full Tracked: Heavy, M88A2	9-2350-292

INSERT LATEST CHANGED PAGES/WORK PACKAGES. DESTROY SUPERSEDED DATA.

LIST OF EFFECTIVE PAGES/WORK PACKAGES

Date of issue for original and changed pages/work packages are:

Original 0 30 September 2005

TOTAL NUMBER OF PAGES FOR FRONT AND REAR MATTER IS 28
TOTAL NUMBER OF WORK PACKAGES IS 17 CONSISTING OF THE FOLLOWING:

Cover	0
Blank	0
a/b blank	0
A/B blank	0
i-iv blank	0
WP 0001 00 (2 pages) ...	0
Chapter 1 Title Page	0
WP 0002 00 (6 pages) ...	0
WP 0003 00 (2 pages) ...	0
Chapter 2 Title Page	0
WP 0004 00 (2 pages) ...	0
WP 0005 00 (4 pages) ...	0
Chapter 3 Title Page	0
WP 0006 00 (2 pages) ...	0
WP 0007 00 (2 pages) ...	0
WP 0008 00 (12 pages) ..	0
WP 0009 00 (2 pages) ...	0
WP 0010 00 (8 pages) ...	0
WP 0011 00 (4 pages) ...	0
WP 0012 00 (16 pages) ..	0
WP 0013 00 (2 pages) ...	0
Chapter 4 Title Page	0
WP 0014 00 (2 pages) ...	0
WP 0015 00 (22 pages) ..	0
WP 0016 00 (2 pages) ...	0
WP 0017 00 (2 pages) ...	0
Index (4 pages)	0
DA Form 2028 Sample ...	0
DA Form 2028 (6 pages) .	0
Authentication (2 pages) .	0
Conversion Table (2 pages)	0
Measurement Page	0
PIN	0

*Zero in this column indicates an original page or work package

A/B blank

DIRECT SUPPORT AND GENERAL SUPPORT MAINTENANCE MANUAL

(INCLUDING REPAIR PARTS AND SPECIAL TOOLS LIST)

for

TURBOSUPERCHARGER

MODEL 5HDR

**NSN 2950-00-397-3384 (11668377-1),
2950-01-167-1700 (187727), 2950-01-432-0369 (655595-3), AND
2950-01-434-3229 (655595-4)**

REPORTING ERRORS AND RECOMMENDING IMPROVEMENTS

You can help improve this publication. If you find any mistakes or if you know of a way to improve the procedures, please let us know. Submit your DA Form 2028 (Recommended Changes to Equipment Technical Publications) through the Internet, on the Army Electronic Product Support (AEPS) website. The Internet address is <https://aeps.ria.army.mil>. If you need a password, scroll down and click on "ACCESS REQUEST FORM". The DA Form 2028 is located in the ON-LINE FORMS PROCESSING section of the AEPS. Fill out the form and click on SUBMIT. Using this form on the AEPS will enable us to respond quicker to your comments and better manage the DA Form 2028 program. You may also mail, fax or email your letter or DA Form 2028 direct to: Technical Publication Information Office, TACOM-RI, 1 Rock Island Arsenal, Rock Island, IL 61299-7630. The email address is TACOM-TECH-PUBS@ria.army.mil. The fax number is DSN 793-0726 or Commercial (309) 782-0726.

A reply will be furnished directly to you.

Distribution Statement A: Approved for public release; distribution is unlimited.

TABLE OF CONTENTS

WP Sequence

HOW TO USE THIS MANUAL

General Information WP 0001 00

CHAPTER 1 INTRODUCTION

Equipment Description and Data WP 0002 00

Theory of Operation WP 0003 00

CHAPTER 2 MAINTENANCE INSTRUCTIONS

Repair Parts, Special Tools, and Support Equipment WP 0004 00

Troubleshooting Instructions WP 0005 00

CHAPTER 3 MAINTENANCE PROCEDURES

General Maintenance Instructions WP 0006 00

Cleaning the Turbo Before Disassembly WP 0007 00

Disassembly of Turbo Into Component Parts WP 0008 00

Cleaning of Component Parts WP 0009 00

Inspection of Component Parts WP 0010 00

Repair of Component Parts WP 0011 00

Assembly and Operational Testing WP 0012 00

Preservation and Storage WP 0013 00

CHAPTER 4 SUPPORTING INFORMATION

References	WP 0014 00
Repair Parts and Special Tools List	WP 0015 00
Expendable and Durable Items List	WP 0016 00
Tool Identification List	WP 0017 00
Alphabetical Index	INDEX-1

HOW TO USE THIS MANUAL

This technical manual describes the Direct Support (DS) and General Support (GS) maintenance and repair requirements for the Model 5HDR Turbosupercharger. To use the maintenance procedures in this manual properly, you must familiarize yourself with the entire procedure before beginning the maintenance task. Information in this manual is divided into four chapters containing work packages and supporting work packages and an index. Work packages are numbered sequentially within each chapter. Use the table of contents to quickly find the parts of the manual used most often.

Chapter 1 contains the general introductory information and a description of the characteristics, capabilities, and major components of the turbosuperchargers. A nomenclature cross-reference list is provided in WP 0001 00 which compares common used in the manual with official nomenclature when a difference exists. This should help you locate repair parts in the Repair Parts and Special Tools List by official nomenclature.

Chapter 2 lists and illustrates common and special tools required to repair the turbosupercharger. This chapter also contains instructions for inspecting and troubleshooting the turbosupercharger.

Chapter 3 contains the procedures for disassembly, cleaning, inspection, repair, and assembly of the turbosupercharger. Lubrication instructions and testing, as well as packing and preservation procedures, are contained in Chapter 4. Throughout the disassembly portion of the chapter, you are instructed to remove and discard certain items such as gaskets, seals, and bearings. These disposable parts are furnished in a parts kit (refer to the Repair Parts and Special Tools List in WP 0014 00). All kit parts listed must be used during assembly.

Chapter 4 contains all supporting information.

WP 0013 00, References, provides a listing of Army publications which apply to this manual.

WP 0014 00 is the Repair Parts and Special Tools List.

WP 0015 00, Expendable and Durable Items List, is a list of consumable material required to maintain the turbosupercharger at DS/GS level.

WP 0016 00 is a Tool Identification List.

An alphabetical index is also provided at the end of this manual, and a metric conversion table is included on the inside back cover.

GENERAL INFORMATION**0001 00**

THIS WORK PACKAGE COVERS:General Information

SCOPE

Type of Manual: This technical manual contains instructions for maintenance and repair of the Model 5HDR Turbosupercharger at the Direct and General Support levels.

Equipment Identification: There are four configurations of Model 5HDR turbosupercharger covered in this manual. Part numbers 11668377-1 (standard, no longer available) and 187727 (clean air) can be mounted on either the right or left bank of various AVDS-1790 series engines. Part numbers 655595-3 (right bank) and 655595-4 (left bank) are used on AVDS-1790-8CR engines.

Purpose of the Equipment: Turbosuperchargers are basically centrifugal blowers driven by engine exhaust gases which deliver high volumes of compressed air to the engine intake manifold. Engines with turbosuperchargers are able to develop more power per unit of fuel consumed.

MAINTENANCE FORMS, RECORDS AND REPORTS

Department of the Army forms and records used for equipment maintenance will be those prescribed by DA PAM 750-8, the Army Maintenance Management System (TAMMS) Operators Manual.

CORROSION PREVENTION AND CONTROL

Corrosion Prevention and Control (CPC) of Army materiel is a continuing concern. It is important that any corrosion problem with the turbocharger be reported so that improvements can be made to prevent the problem in the future. While corrosion is typically associated with rusting of metals, it can also include deterioration of other materials such as rubber and plastic. Unusual cracking, softening, swelling, or breaking of these materials may be a corrosion problem. If a corrosion problem is identified, it can be reported using SF 368, (Product Quality Deficiency Report). Use of keywords such as "corrosion", "rust", "deterioration", or "cracking" will ensure that the information is identified as a CPC problem. SF 368 should be submitted to the address specified in DA PAM 750-8.

DESTRUCTION OF ARMY MATERIEL TO PREVENT ENEMY USE

Refer to TM 750-244-6 for procedures on how to destroy the starter.

Below are some general guidelines to follow in destruction of equipment to prevent enemy use.

Destruction of equipment, when subject to capture or abandonment in a combat zone, will be undertaken only when such action is necessary in accordance with orders of, or policy established by the Army commander.

In general, destruction of essential parts, followed by burning, will usually be sufficient to render equipment useless. Time is usually critical.

Material must be damaged so that it cannot be restored to usable condition by either repair or cannibalization. If lack of time or personnel prevents destruction of all parts, give priority to destruction of parts hardest to replace. It is important that the same parts be destroyed on all starters to prevent construction of one complete starter from several damaged ones.

PREPARATION FOR STORAGE OF EQUIPMENT

Instructions for preservation administrative storage of your turbosupercharger are contained in WP 0012 00.

QUALITY OF MATERIAL

Material used for replacement, repair, or modification must meet the requirements of this manual. If quality of material requirements are not stated in this manual, the material must meet the requirements of the drawings, standards, specifications, or approved engineering change proposals applicable to the subject equipment.

NOMENCLATURE CROSS REFERENCE LIST

This list includes nomenclature cross-references used in this manual.

<u>COMMON NAME</u>	<u>OFFICIAL NOMENCLATURE</u>
Turbo, Turbocharger	Turbosupercharger, Model 5HDR
Cap screws	Screws, Cap, Hexagon Head
Oil drain tube	Tube Assembly, Metal
Nut	Nut, Self-locking, Hexagon
Compressor wheel	Impeller, Fan, Axial
Compressor wheel shims	Shim, Endplay Adjusting
Thrust ring	Ring, Turbosupercharger
Locking plate	Locking Plate, Nut and Bolt
Shield	Shield, Turbosupercharger
Backplate	Backplate, Turbine
Cap screws	Screws, Externally Relieved Body
Filter	Filter, Air, Electrostatic
Compressor cover adapter	Adapter, Straight, Tube to Boss
Turbine wheel and shaft assembly	Turbine Wheel Assembly

REPORTING EQUIPMENT IMPROVEMENT RECOMMENDATIONS (EIRs)

If your turbosupercharger needs improvement, let us know. You, the user, are the only one who can tell us what you don't like about your equipment. Let us know why you don't like the design. Put it on an SF 368 (Quality Deficiency Report). Mail it to us at U.S. Army Tank-automotive and Armaments Command, Warren MI 48397-5000, ATTN: AMSTA - MB. We'll send you a reply.

END OF WORK PACKAGE

CHAPTER 1

INTRODUCTION

EQUIPMENT DESCRIPTION AND DATA**0002 00****THIS WORK PACKAGE COVERS:**

Equipment Description and Data

DESCRIPTION**NOTE**

Throughout the remainder of this technical manual, turbosuperchargers will be referred to also as turbos or turbochargers.

1. General. Turbochargers are mounted on the rear right and left sides of all series AVDS-1790 engines. They use engine exhaust gases to drive a turbine and generate compressed air which is blown at high velocity into the engine air intake manifold. This turbocharging action maintains air intake pressure at a high level and results in an increase in engine output power.

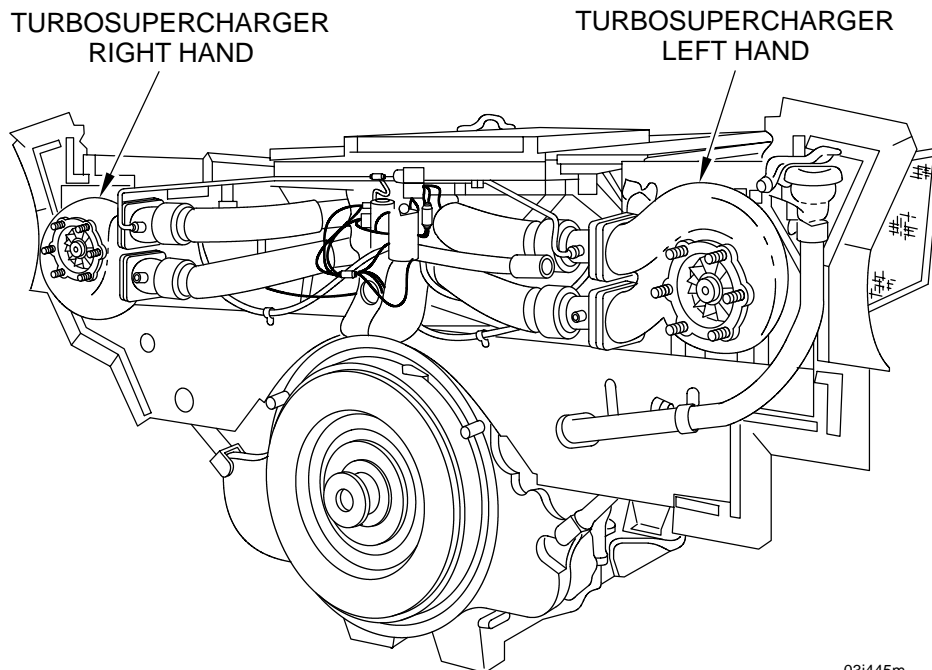

03i445m

Turbosuperchargers in mounted locations.

EQUIPMENT DESCRIPTION AND DATA - CONTINUED

0002 00

2. Lubrication. Your turbocharger is pressure lubricated by the engine lubricating system through an external hose connected from the bearing housing to the engine oil filter. Oil flows through the bearing housing, around the sleeve bearings, and returns to the engine oil pan via bearing clearances and the oil drain tube. Metal seal rings prevent oil from entering the turbine housing and compressor cover.

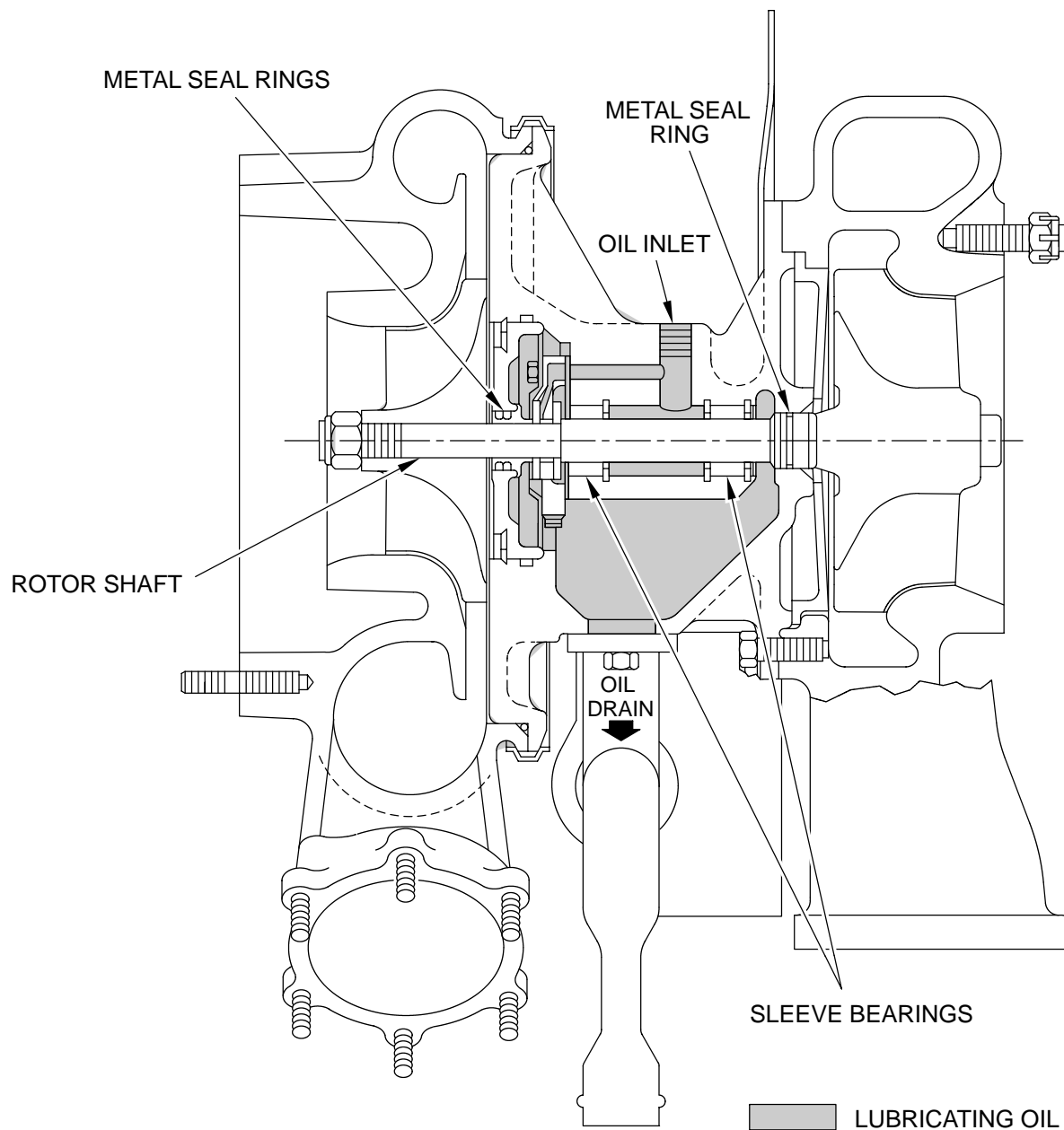

Lubrication System.

03i447m

EQUIPMENT DESCRIPTION AND DATA - CONTINUED**0002 00**

3. Difference Between Models. Turbosupercharger part number 11668377-1 used on engine models AVDS-1790-2C, AVDS-1790-2D, and AVDS-1790-2DR (no longer available).

Turbosupercharger part number 187727 (clean air) used on engine models AVDS-1790-2CA, AVDS-1790-2DA, and as a replacement for part number 11668377.

With the exception of the dust detector assembly incorporated into the compressor housing of turbosupercharger part number 187727, these two models are identical and can be used for either left or right bank applications (proper orientation as required). When replacing 11668377-1 turbosupercharger, use part number 187727 and cap off clean air fittings with MS51532B-B5S (NSN: 4730-00-948-9682) and MS51532B-B4S (NSN: 4730-01-127-3942) caps.

Turbosupercharger part numbers 655595-3 (right bank) and 655595-4 (left bank) are used on engine model AVDS-1790-8CR. The only difference between the -3 and -4 models are orientation and heat shields. For replacement, order 655595-3 and use as is for right bank, replace heat shield and re-orient for left bank.

Assembly/Disassembly/Inspection procedures are identical for all three models. Difference in parts/part numbers are identified in Appendix B.

NOTE

For a complete description of the Dust Detector system for "clean air" engine models AVDS-1790-2CA, AVDS-1790-2DA, and AVDS-1790-8CR refer to TM 9-2815-247-34.

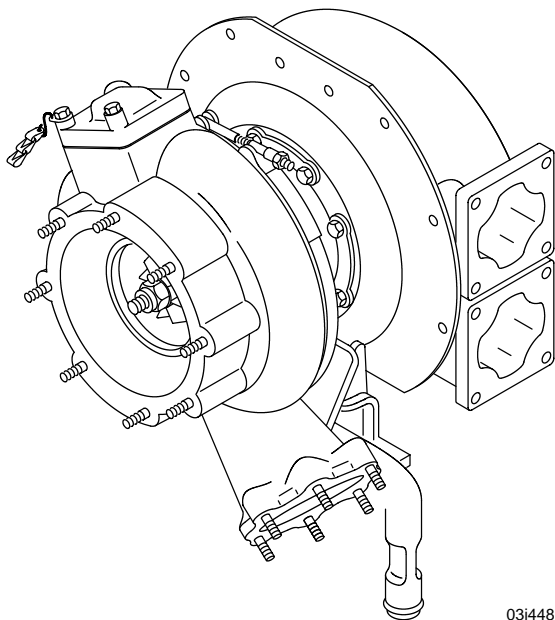

"Clean air" turbosupercharger.

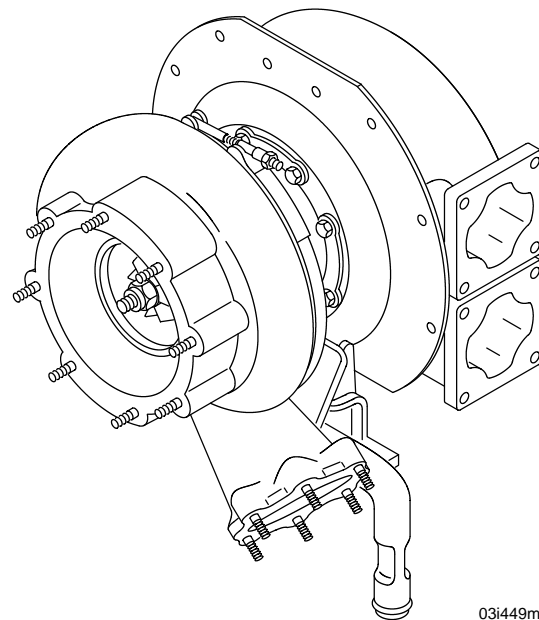

Standard turbosupercharger.

EQUIPMENT DESCRIPTION AND DATA - CONTINUED

0002 00

4. Difference Between Right and Left Hand Mounting. All configurations of the turbo discussed in this manual can be either right or left hand mounted by indexing the turbine housing and compressor cover according to the mounting location and engine model. Also, the position of the oil drain tube is reversed for right or left hand use. For engine model AVDS-1790-2DR the turbosupercharger heat shields are removed and discarded before the turbos are mounted. Part number 655595-3 and 655595-4 turbosuperchargers have different heat shields. Ensure proper shield is used for left or right bank application.

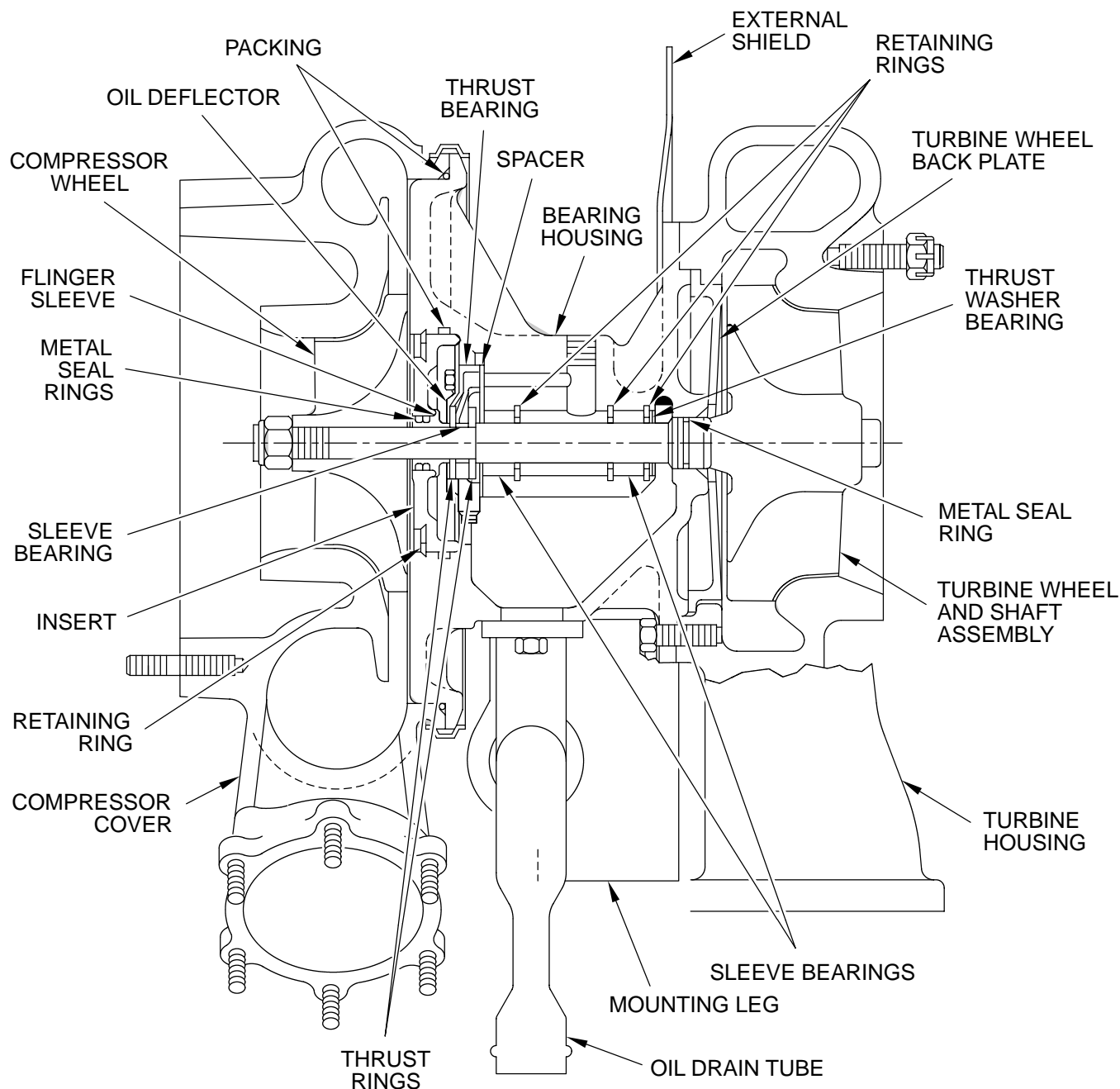

Turbosupercharger - sectional view.

03i450m

EQUIPMENT DATA

1. General.

Model 5HDR
 Mounting Universal

2. Specifications.

Maximum revolutions per minute 65,000
 Diameter of compressor air inlet opening 6.50 in.
 Diameter of compressor air outlet opening 3.62 in.
 Diameter of each turbine exhaust inlet opening 3.00 in.
 Diameter of turbine exhaust outlet opening 4.26 in.
 Oil inlet pressure to bearing housing 40 to 70 psi
 Oil outlet pressure from bearing housing Crankcase pressure

IDENTIFICATION PLATE

The turbosupercharger identification plate is located on the bearing housing above the mounting leg.

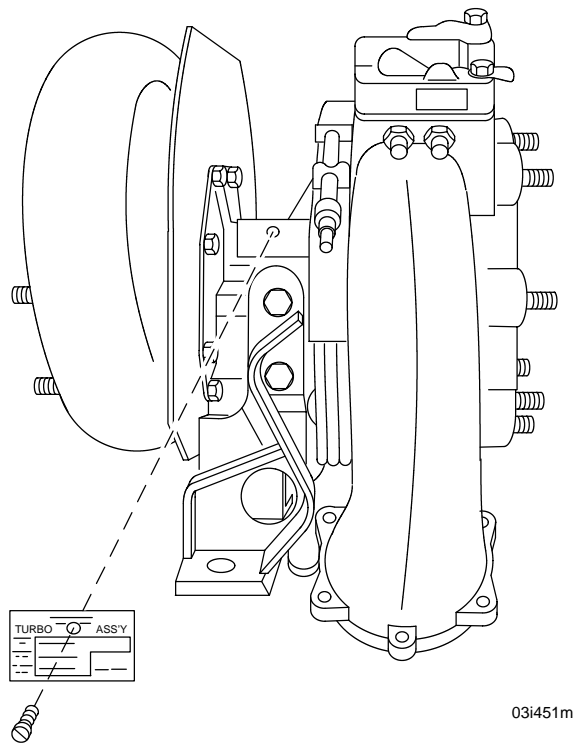

Location of Turbosupercharger Identification Plate.

END OF WORK PACKAGE

THEORY OF OPERATION

0003 00**THIS WORK PACKAGE COVERS:**Theory of Operation

OPERATION

- a. Exhaust gases from the engine exhaust manifold enter the turbo through ports in the turbine housing.
- b. Pressure and heat from the exhaust gases turn the turbine wheel. The gases then leave the turbine housing through the exhaust outlet and are expelled through the vehicle exhaust system.
- c. The turbine wheel and the compressor wheel are mounted on a common rotor shaft. When the turbine wheel spins, so does the compressor wheel.
- d. The spinning compressor wheel draws air from the vehicle air filter into the compressor cover.
- e. The air is compressed and blown out of the compressor cover through the outlet port, where it enters the vehicle air induction system.
- f. The increased volume and density of air that is delivered to the engine cylinders causes a corresponding increase in engine output power.
- g. The bearing housing supports the rotor shaft and its sleeve bearings. Lubrication of bearings and other turbocharger moving parts takes place in the bearing housing.

END OF WORK PACKAGE

CHAPTER 2

MAINTENANCE INSTRUCTIONS

REPAIR PARTS, SPECIAL TOOLS, AND SUPPORT EQUIPMENT

0004 00

THIS WORK PACKAGE COVERS:

Common Tools and Equipment, Special Tools, Repair Parts, and Manufactured Items

COMMON TOOLS AND EQUIPMENT

For authorized common tools and equipment, refer to the Modified Table of Organization and Equipment (MTOE) applicable to your unit.

SPECIAL TOOLS

WP 0015 00 contains a listing and illustrations of the special tools required to maintain and repair turbosuperchargers at the DS/GS level.

REPAIR PARTS

Repair parts are listed and illustrated in WP 0015 00 of this manual.

MANUFACTURED ITEMS

An improvised support block may be fabricated locally for use in disassembling the turbosupercharger. It should be a hardwood block 3 X 3 X 1-1/8 inches.

END OF WORK PACKAGE

TROUBLESHOOTING INSTRUCTIONS**0005 00****THIS WORK PACKAGE COVERS:**

Troubleshooting Instructions and Malfunction/Corrective Action Table

TROUBLESHOOTING INSTRUCTIONS

1. **General.** The instructions and information in this section apply to defective turbosuperchargers once they have been removed from the engine.
 - a. When the malfunction is known, use the inspection procedures to make sure the diagnosis is correct and to determine if there are further problems with the turbo not indicated on the repair tag.
 - b. When the malfunction is not known, use the inspection procedures to detect and identify the problem. The inspection is particularly important in this case because it is often the only available way of finding out what is wrong without completely disassembling the turbo.
 - c. When you have identified all the problems with a defective turbosupercharger, then use the Troubleshooting Guide, Table 2-1, to find out the probable causes and corrective actions.
2. **Inspection.** Upon receipt, you should thoroughly inspect and check the defective turbosupercharger according to the following procedures.
 - a. **Visual Checks.** Visually inspect the turbo for:
 - 1) Stripped, damaged or missing studs.
 - 2) Cracked or broken mounting legs; cracked, bent or restricted oil drain tube.
 - 3) Cracked or damaged compressor cover, turbine housing, or bearing housing.
 - 4) Damaged or eroded (worn) compressor wheel blades.

NOTE

If compressor wheel blades are worn, look for dust or sand in the compressor housing inlet or outlet openings.

- 5) Peened or feathered edges on compressor wheel or turbine wheel blade tips.
- 6) Compressor wheel or turbine wheel which does not turn freely when spun by hand.
- 7) Excess oil in the compressor cover or turbine housing.

NOTE

A trace of oil in these areas is normal. During long periods of idling or under certain peak acceleration conditions, some oil may pass through the seals. However, this normal leakage is small, and will not affect the oil consumption rate. Also, heavy oily soot deposits in the turbine housing or on the turbine wheel are usually caused by improper engine operation or engine malfunction.

- b. **Check Radial Movement.** Radial movement is the motion of the rotor shaft laterally in the bore of the bearing housing. Too much radial movement can cause the compressor wheel and turbine wheel to rub against their respective housings. Check radial movement by performing the following steps.
 - 1) Visually check the compressor cover outlet for excessive lubricating oil.
 - 2) Push both wheels laterally in opposite directions, and visually check to ensure that there is clearance between the compressor wheel and the compressor cover at the extreme radial movement.
 - 3) Check to ensure that there is clearance between the turbine wheel and the turbine housing at the extreme radial movement.
 - 4) Repeat steps (2) and (3) at 90 degree intervals around the shaft.
 - 5) If there is no significant evidence of lubricating oil at the compressor cover outlet, and there is visual clearance between the compressor and turbine wheels and their respective housing, and the wheels turn freely when spun by hand, the turbo is approved for service with regard to radial movement.

TROUBLESHOOTING INSTRUCTIONS - CONTINUED**0005 00**

- c. **Check End Play.** End play is the distance the rotor shaft travels in and out of the bore in the bearing housing. Check the end play by performing the following steps.
- 1) Clean the turbine wheel hub.
 - 2) Secure the turbocharger and attach a dial indicator (1) to the turbine housing (or other flat surface) with a clamp or magnetic base holder. Position the indicator plunger on the turbine wheel hub (2).
 - 3) Move the turbine wheel in and out as far as possible and check the distance traveled on the indicator.

NOTE

If there is lubricating oil in the bearing housing, the initial end play reading could be inaccurate. To ensure that an accurate reading is obtained, you should move the turbine wheel in and out several times to displace the oil before taking the end play reading.

- 4) Total end play must be greater than 0.004 inch and less than 0.006 inch.
3. **Corrective Action.** Any broken or damaged components discovered during the visual checks should be marked for repair. If no additional problems are found during inspection or are indicated on the repair tag, you should thoroughly clean the turbo (WP 0007 00), replace the broken or damaged components, and return the unit to service. For all other problems, refer to Table 2-1, Troubleshooting guide.

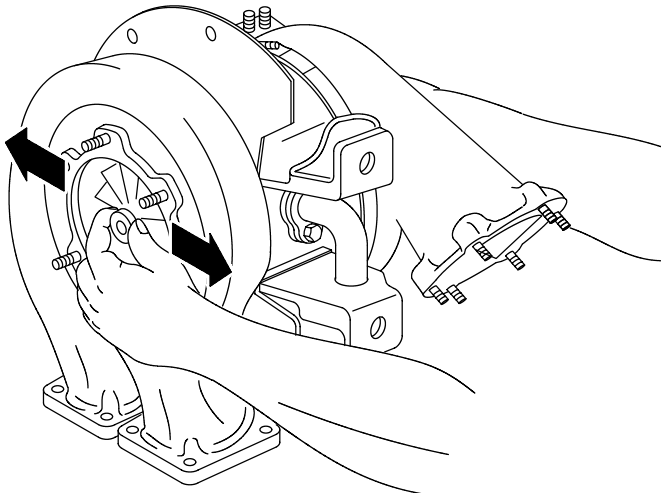

03i452m

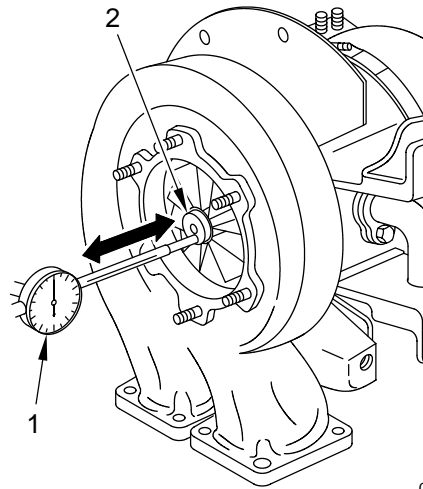
Checking radial movement.

03i453m

Checking end play.

TROUBLESHOOTING INSTRUCTIONS - CONTINUED

0005 00

TABLE 2-1. TROUBLESHOOTING

MALFUNCTION	PROBABLE CAUSE(S)	CORRECTIVE ACTION
1. Compressor wheel or turbine wheel does not turn freely when spun by hand.	a. Dirt build up behind compressor wheel, or dirt or carbon build-up behind turbine wheel.	Disassemble and clean turbo. Refer to WP 0008 00-1.
	b. Foreign object damage, worn bearings or thrust surfaces, or damaged compressor wheel or turbine wheel.	Disassemble turbo and replace worn or damaged parts. Refer to WP 0008 00-1.
2. Evidence of compressor wheel rubbing.	Worn or damaged bearings or thrust rings, worn bore in bearing housing; worn or bent shaft, or bent or damaged compressor wheel.	Disassemble the turbo and replace worn or damaged parts. Refer to WP 0008 00-1.
3. Evidence of turbine wheel rubbing.	Worn sleeve bearing, or bent or damaged turbine wheel, or worn bore in bearing housing; worn or bent shaft.	Disassemble the turbo and replace worn or damaged parts. Refer to WP 0008 00-1.
4. Excessive radial movement. Refer to WP 0005 00-1.	Worn sleeve bearings, or worn shaft and turbine wheel assembly, or worn bore in bearing housing.	Disassemble the turbo and replace worn or damaged parts. Refer to WP 0008 00-1.
5. Excessive oil leaking into compressor housing from bearing housing.	Flinger sleeve metal seal ring worn or broken.	Disassemble the turbo and replace flinger sleeve metal seal ring. Refer to WP 0008 00-1.
6. Excessive oil leaking into the turbine from the bearing housing.	Turbine wheel and shaft assembly metal seal ring worn or broken.	Disassemble the turbo and replace metal seal ring. Refer to WP 0008 00-1.
7. End play greater than 0.006 inch.	Worn thrust surfaces on thrust bearing and thrust rings.	Disassemble the turbo and replace worn or damaged parts. Refer to WP 0008 00-1.
8. End play less than 0.004 inch.	Dirt build-up behind turbine wheel or dirt build-up behind compressor wheel.	Disassemble and clean turbo. Refer to WP 0008 00-1.
9. Turbo makes excessive noise.	Dirt build-up between bearings and housing.	Disassemble and clean turbo. Replace worn or damaged bearings. Refer to WP 0008 00-1.

END OF WORK PACKAGE

CHAPTER 3

MAINTENANCE PROCEDURES

GENERAL MAINTENANCE INSTRUCTIONS

0006 00**THIS WORK PACKAGE COVERS:**General Maintenance Instructions

PURPOSE

This chapter contains instructions for cleaning before disassembly; disassembly; cleaning, inspection, and repair of component parts; assembly; operational testing; and storage of turbosuperchargers after they have been removed from the engine.

APPLICATION

Procedures in this chapter, except those involving components of the dust detector system, apply to all turbo configurations covered by this manual. Maintenance operations for dust detector components apply to the "clean air" turbos (part numbers 187727, 655595-3, and 655595-4) only.

ORGANIZATION

Each maintenance work task described in this work package will be organized in the following manner:

- a. This Work Package Covers. Provides a description of the scope of the work package.
- b. Initial Setup. lists the information you will need before starting the procedure, such as:
 - 1) Tool requirements.
 - 2) Material and supplies requirements.
 - 3) Personnel requirements.
 - 4) Equipment condition.
- c. Procedure. Outlines the process for performing the task in step-by-step sequence.

ILLUSTRATIONS

Each illustration, used to describe a procedural step, will be located following that step(s).

Illustrations in WP 0007 00 are derived from a "clean air" turbo assembled for typical left hand mounting.

CONVERSIONS

At the time of publication of this manual, a program is underway for converting all standard Model 5HDR Turbo-superchargers to the "clean air" configuration. Instructions for performing this conversion are contained in Maintenance Work Order (MWO) 9-2815-220-50-1.

END OF WORK PACKAGE

CLEANING THE TURBO BEFORE DISASSEMBLY**0007 00****THIS WORK PACKAGE COVERS:**

Cleaning

INITIAL SETUP:**Materials/Parts**

Hard bristle brush (item 5, WP 0016 00)
Plastic scraper (item 8, WP 0016 00)
Goggles (item 6, WP 0016 00)
Rubber gloves (item 7, WP 0016 00)
Solvent (item 3, WP 0016 00)
Rag, wiping, cotton (item 1, WP 0016 00)

Equipment Condition

Turbo on workbench

NOTE

Before beginning the disassembly of the turbo, thoroughly clean and degrease exterior surfaces using the procedure outlined below.

CLEANING

1. Drain bearing housing of lubricant from oil drain tube (2).
2. Tape oil inlet port (1), oil drain tube opening (2), and threaded hose adapters (3).

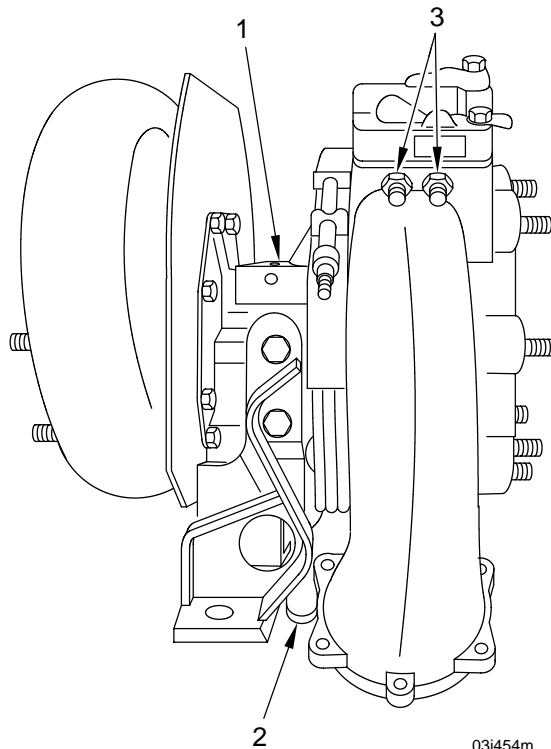

WARNING

Cleaning solvent is flammable! Use only in well ventilated areas. Keep away from flame, sparks, or heat. Avoid contact with eyes, mouth, or skin. Wear rubber gloves to prevent skin irritation.

CAUTION

Never use a wire brush or steel blade scraper.

3. Using bristle brush, plastic scraper, and solvent, remove dirt, oil, and any other contaminants from all exterior surfaces.
4. Use cloth moistened with solvent to clean hard to reach areas.

WARNING

Line pressure for compressed air used for cleaning shall not exceed 30 psi. Wear appropriate eye protection and gloves. Never direct the compressed air stream at another person.

5. Blow turbo dry with compressed air.

END OF WORK PACKAGE

DISASSEMBLY OF THE TURBO INTO COMPONENT PARTS**0008 00****THIS WORK PACKAGE COVERS:**

Removal

INITIAL SETUP:**Tools and Special Tools**

- General mechanic's tool kit (item 1, WP 0017 00)
- Retaining ring pliers (Fig 4, item 2, WP 0015 00)
- Scriber, machinist's (item 2, WP 0017 00)
- Wood support block (WP 0004 00)

Materials/Parts

- Parts Kit 5705073 (WP 0015 00)

Equipment Condition

- Turbo on workbench
- Oil drained from housing and exterior cleaned (WP 0007 00)

NOTE

Disassemble the turbo according to the following procedure. During disassembly you will be instructed to "remove and discard" certain disposable parts. These items will be replaced during assembly of the turbo with new parts from the turbosupercharger parts kit, part number 5705073. Refer to WP 0015 00.

REMOVAL

1. Removal of Mounting Legs and Oil Drain Tube.
 - a. Remove two cap screws and lockwashers (1).
 - b. Remove outer mounting leg (2).

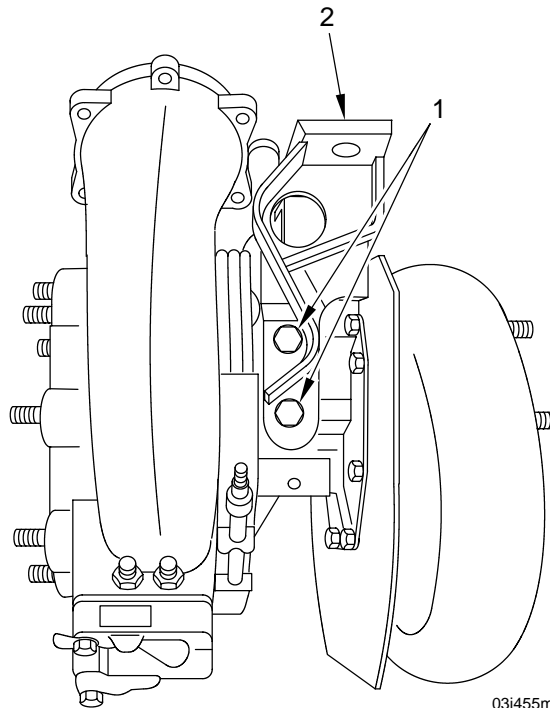

- c. Remove two cap screws and lockwashers (3).
- d. Remove oil drain tube (4). Remove and discard oil drain tube gasket (5).

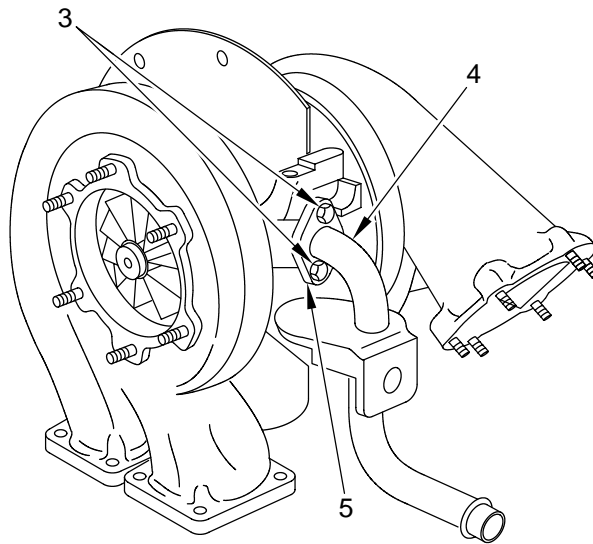

03i456m

- e. Remove two cap screws and lockwashers (6).
- f. Remove inner mounting leg (7).

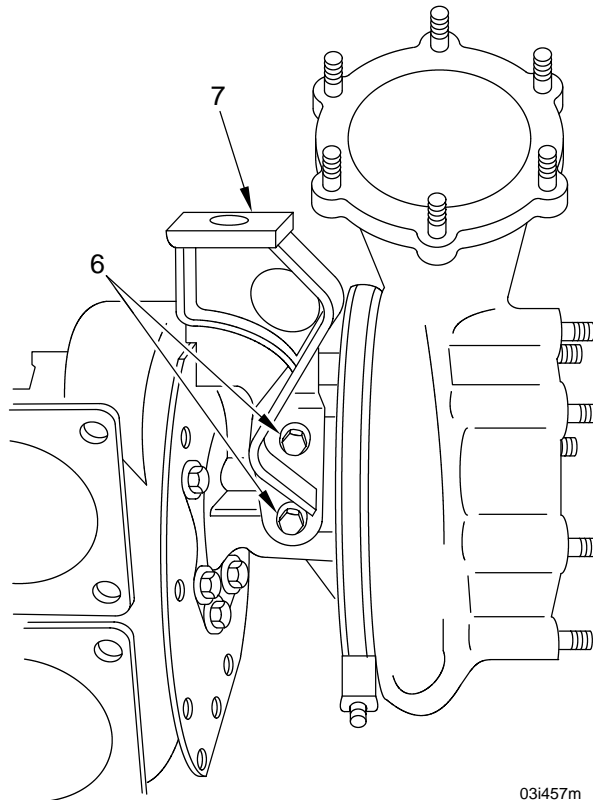

03i457m

DISASSEMBLY OF THE TURBO INTO COMPONENT PARTS - CONTINUED**0008 00****2. Removal of the Compressor Cover and Clamp.**

- a. Using metal scribe, scribe alignment marks on compressor cover (1) and bearing housing (2).

NOTE

If your turbo is a newer model, alignment marks will be cast into the housings, and the above step will not be necessary. Take careful note of the matched alignment marks to ensure proper reassembly.

- b. Remove nut (3) from clamp (4). Loosen clamp and slide it down on bearing housing.

CAUTION

Use care when lifting compressor cover to prevent damage to compressor wheel.

- c. Remove compressor cover.
d. Remove clamp.
e. Remove and discard preformed packing (5) from bearing housing.

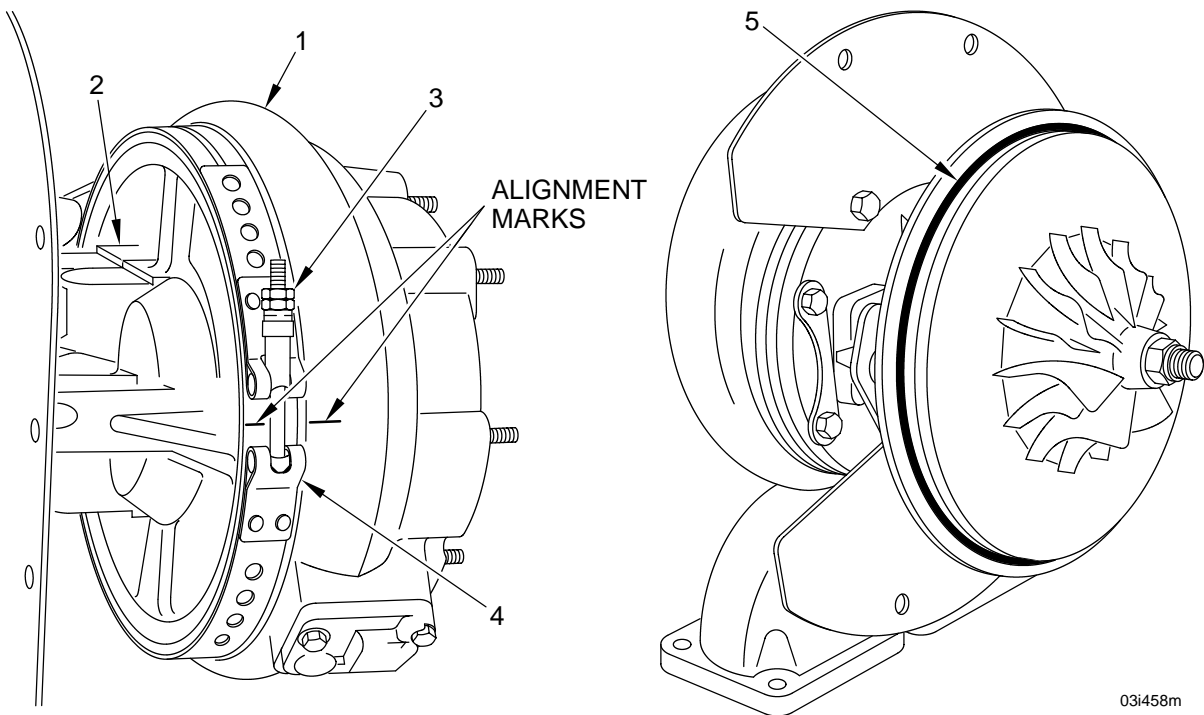

3. Removal of the Compressor Wheel.

- a. Place a 1-1/8 inch 12 point socket and bar (1) on the turbine wheel hub and hold in position.
- b. Using 3/4 inch box end wrench (2), remove and discard compressor wheel lock nut (3).

CAUTION

Use care when removing the compressor wheel to prevent damage to the wheel blades. DO NOT attempt to pry the compressor wheel off the shaft. If the wheel is difficult to remove, work it gently back and forth with your fingers until loose.

- c. Remove compressor wheel (4).

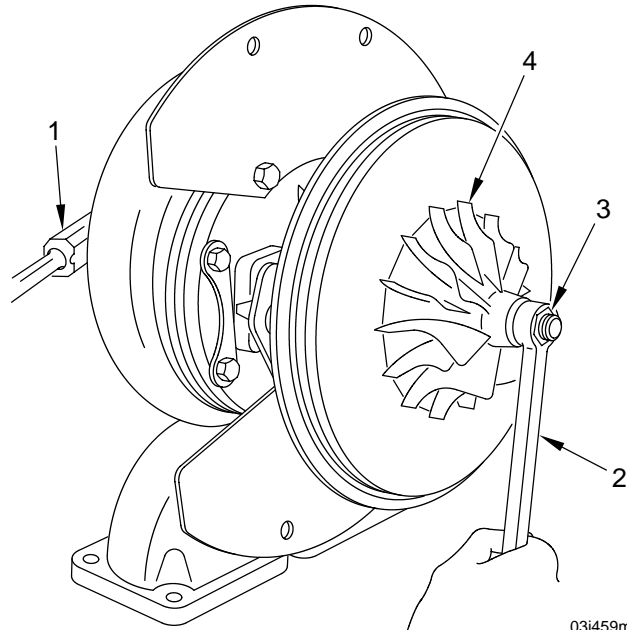

4. Removal of Compressor Wheel Shims, Retaining Ring, and Flinger Sleeve Insert.

- a. Place turbo on turbine housing studs (1) with improvised support block (2) under the turbine wheel. See WP 0004 00.

NOTE

The support block prevents the turbine wheel and shaft assembly from dropping into the turbine housing during disassembly and possibly damaging the wheel blades.

- b. Remove and discard compressor wheel shims (3).

NOTE

Compressor wheel shims may stick to the back of the compressor wheel.

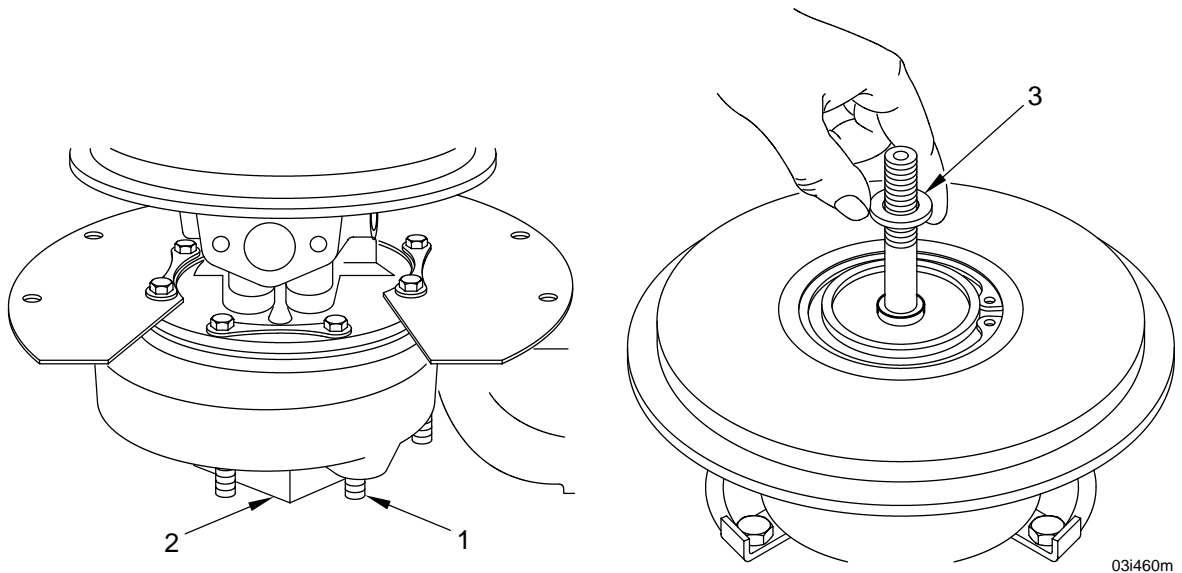

- c. Remove retaining ring (4).
- d. Using two flat head screwdrivers (5), GENTLY pry flinger sleeve insert (6) away from bearing housing until it can be removed by hand. Discard insert.

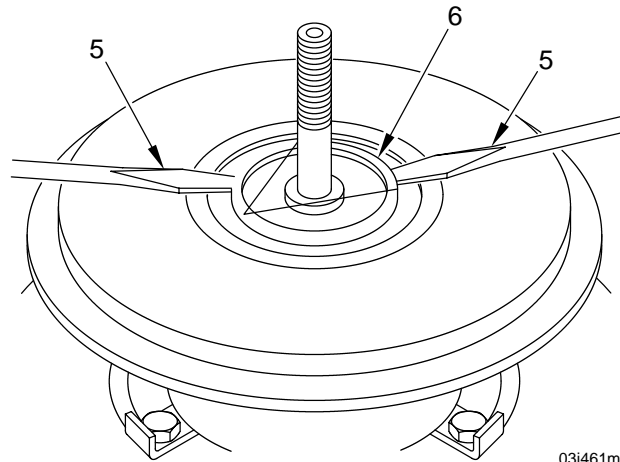
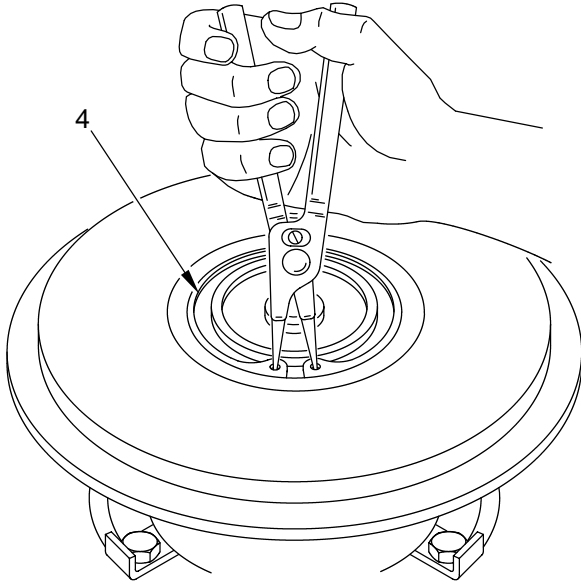

03i461m

5. Removal of Preformed Packing, Metal Seal Rings, Flinger Sleeve, and Oil Deflector.

- a. Remove and discard preformed packing (1).
- b. Remove and discard flinger sleeve (2) and two metal seal rings (3).
- c. Remove and discard three oil deflector screws (4).
- d. Remove oil deflector (5).

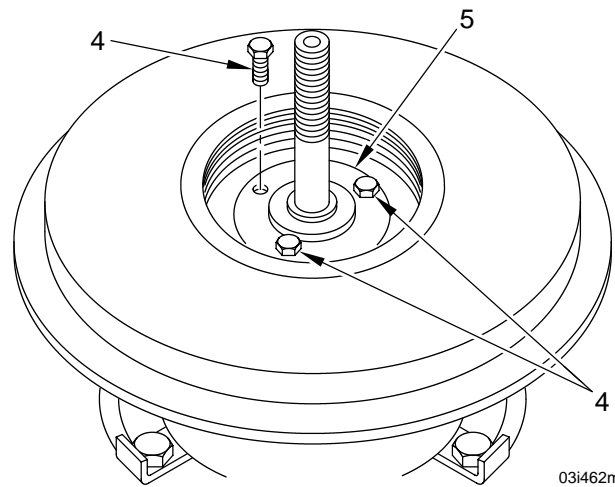
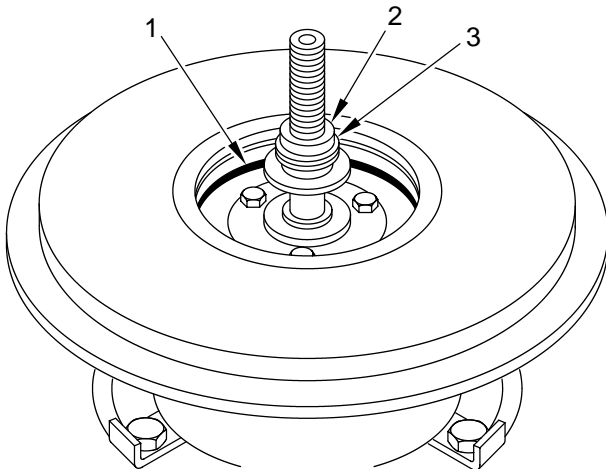

03i462m

DISASSEMBLY OF THE TURBO INTO COMPONENT PARTS - CONTINUED

0008 00

6. Removal of Upper Thrust Ring, Thrust Bearing, Thrust Sleeve Bearing, Lower Thrust Ring, and Spacer.

- a. Remove and discard upper thrust ring (1).
- b. Remove and discard thrust bearing (2).

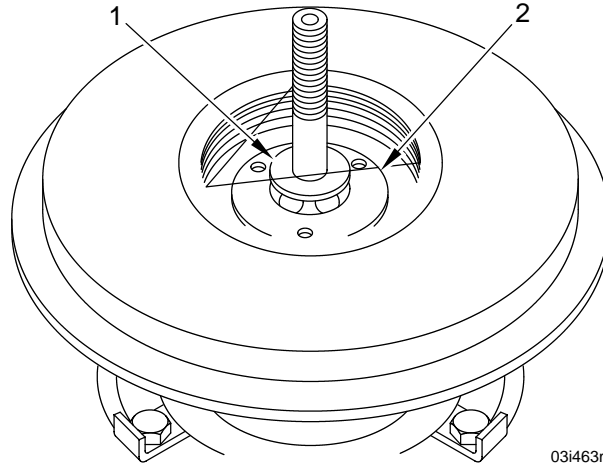

03i463m

- c. Remove and discard thrust sleeve bearing (3).
- d. Remove and discard lower thrust ring (4).
- e. Remove and discard spacer (5).

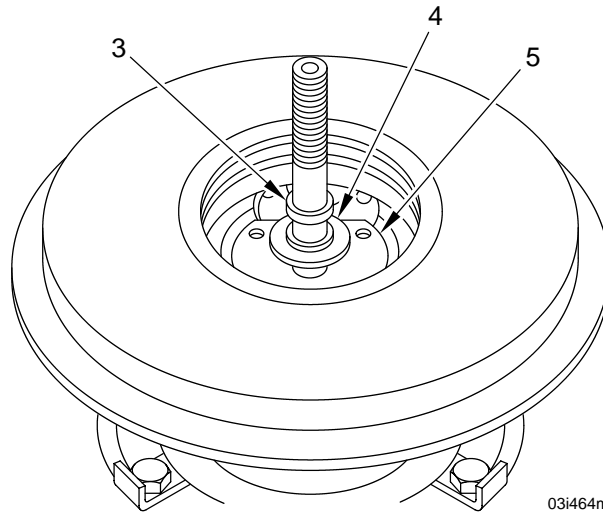

03i464m

7. Removal of the Shield, Bearing Housing, Turbine Wheel and Shaft Assembly and Backplate.

- a. Scribe alignment marks on flanges of bearing-housing (1) and turbine housing (2).

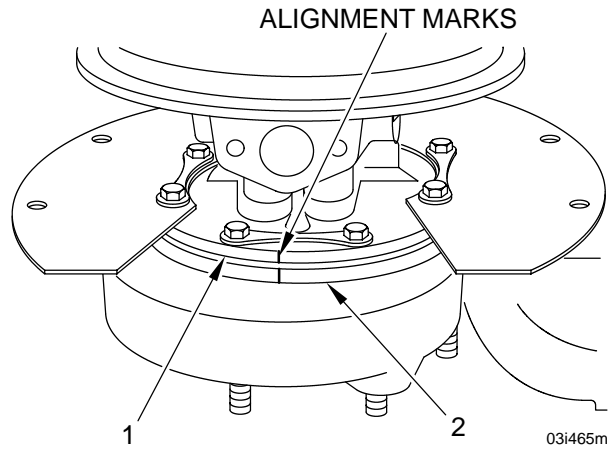

- b. Straighten tabs on locking plates (3).
- c. Remove eight cap screws (4).
- d. Remove and discard four locking plates.
- e. Remove shield (5).

NOTE

You may have difficulty separating the bearing housing from the turbine housing. If so, tap the turbine housing lightly with a soft mallet while lifting the bearing housing.

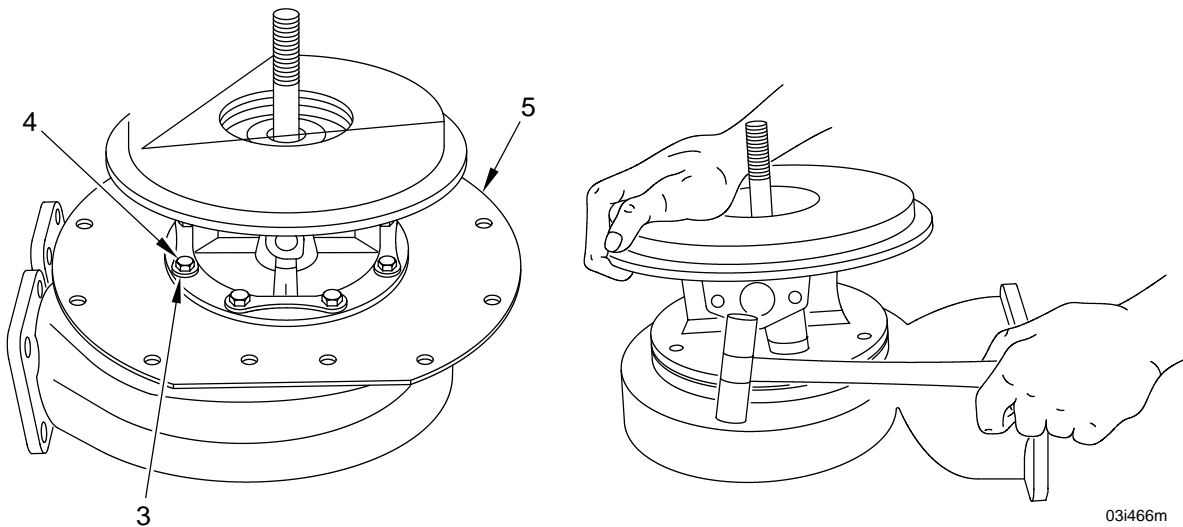

DISASSEMBLY OF THE TURBO INTO COMPONENT PARTS - CONTINUED**0008 00**

- f. Remove the bearing housing by lifting it straight up. The turbine wheel and shaft assembly should remain in the turbine housing.
- g. Remove turbine wheel and shaft assembly (6) with backplate (7) from turbine housing.
- h. Remove backplate from turbine wheel and shaft assembly.

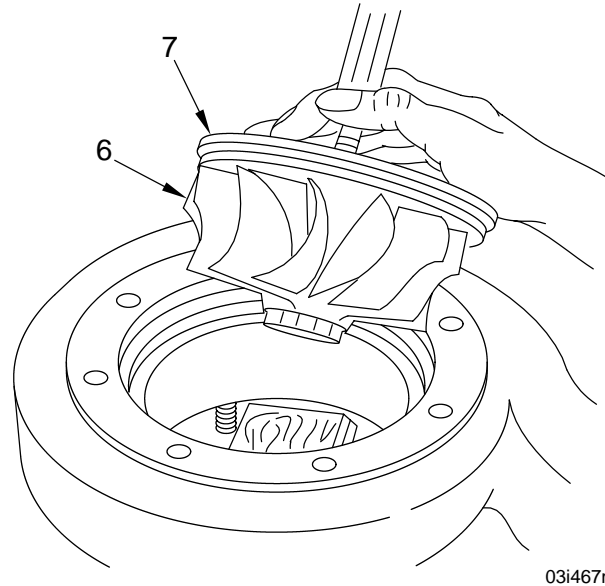

03i467m

8. Removal of Upper Sleeve Bearing, Retaining Rings, Lower Sleeve Bearing, Thrust Washer Bearing, and Metal Seal Ring.

- a. Remove and discard upper sleeve bearing (1) from bearing housing.

CAUTION

When removing retaining rings, use care that they do not scratch the bore of the bearing housing.

- b. Using retaining ring pliers, remove two retaining rings (3).

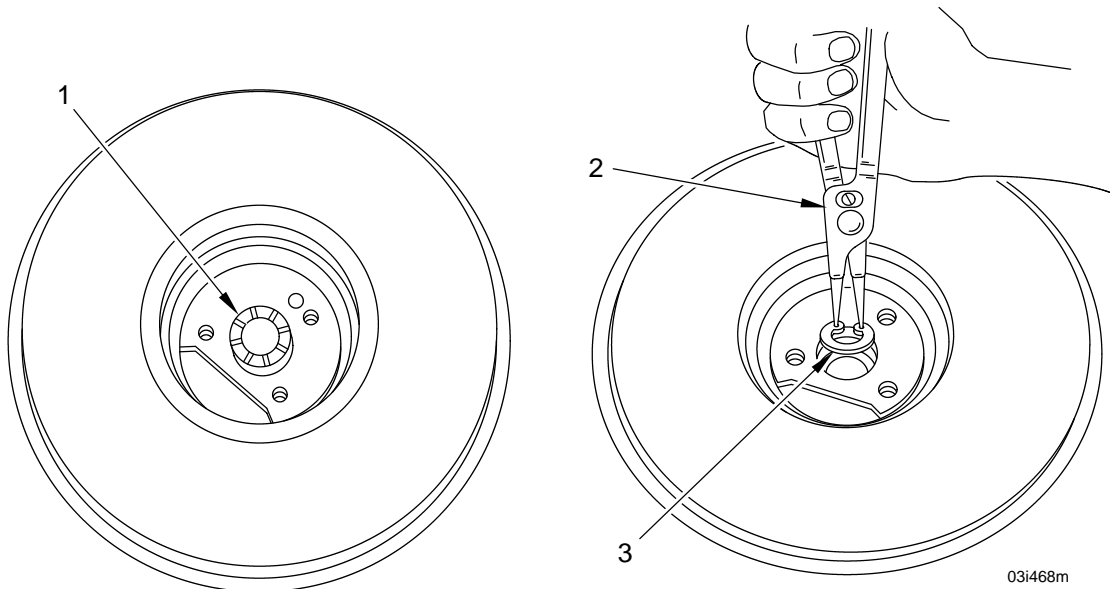

03i468m

- c. Remove and discard lower sleeve bearing (4) and thrust washer bearing (5).

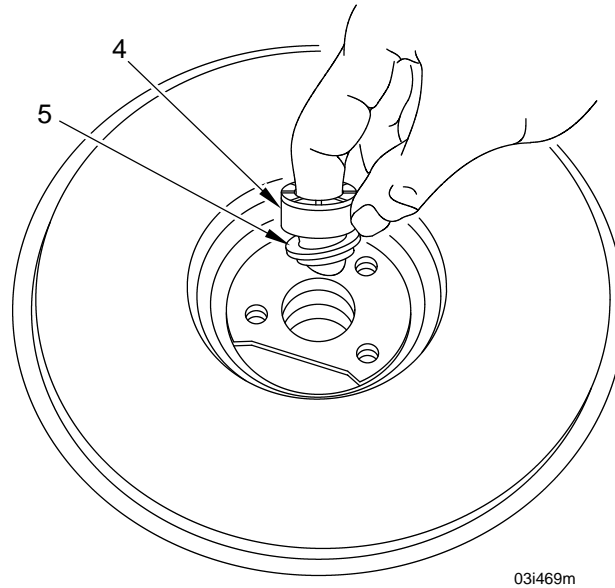

NOTE

It is not necessary to remove the third retaining ring from the bearing housing unless it is worn or damaged. If removal is necessary, use retaining ring pliers.

- d. Remove metal seal ring (6) from turbine wheel and shaft assembly. Discard metal seal ring.

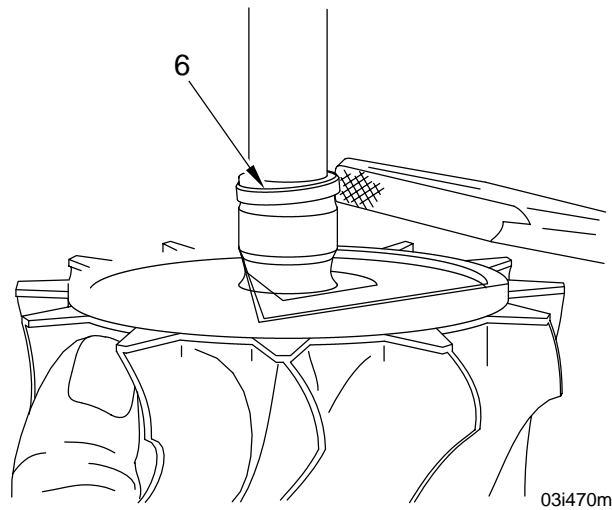

DISASSEMBLY OF THE TURBO INTO COMPONENT PARTS - CONTINUED**0008 00****9. Removal of Dust Detector Cover Packing With Retainer, Chain Fastener, Chain "S" Hook, and Chain.****NOTE**

This procedure applies to "clean air" turbo only.

- a. Remove three cap screws (1), two flat washers (2), and packing with retainer (3).
- b. Discard packing with retainer.
- c. Remove chain fastener (4), chain "S" hook (5), and chain (6) as an assembly.

NOTE

It will not be necessary for you to disassemble the chain fastener, chain "S" hook, and chain unless one or more of these parts show signs of damage or wear.

- d. Remove dust detector cover (7).

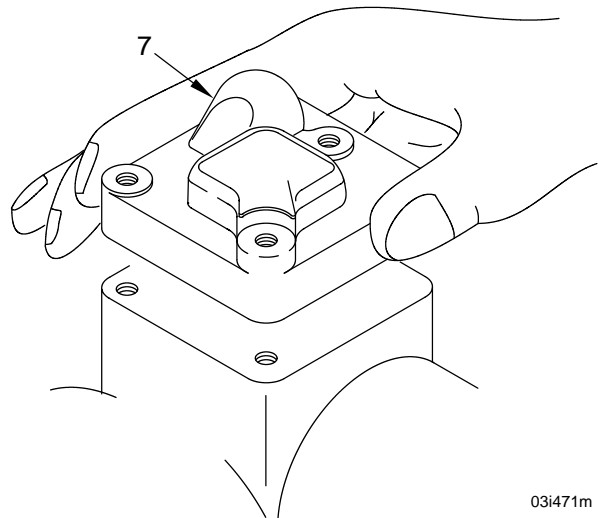
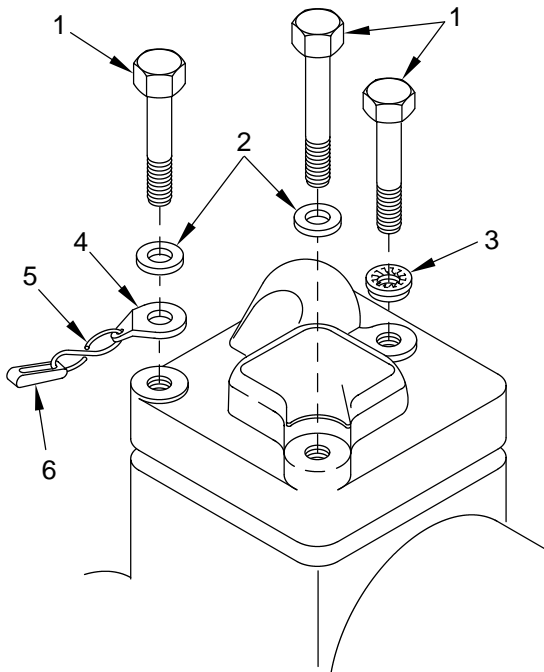

03i471m

10. Removal of Preformed Packings, Filter Retaining Strap, and Filter From Dust Detector Cover.**NOTE**

This procedure applies to "clean air" turbo only.

- a. Remove filter retaining strap (1) and filter (2).
- b. Remove and discard three preformed packings (3) from underside of dust detector cover.

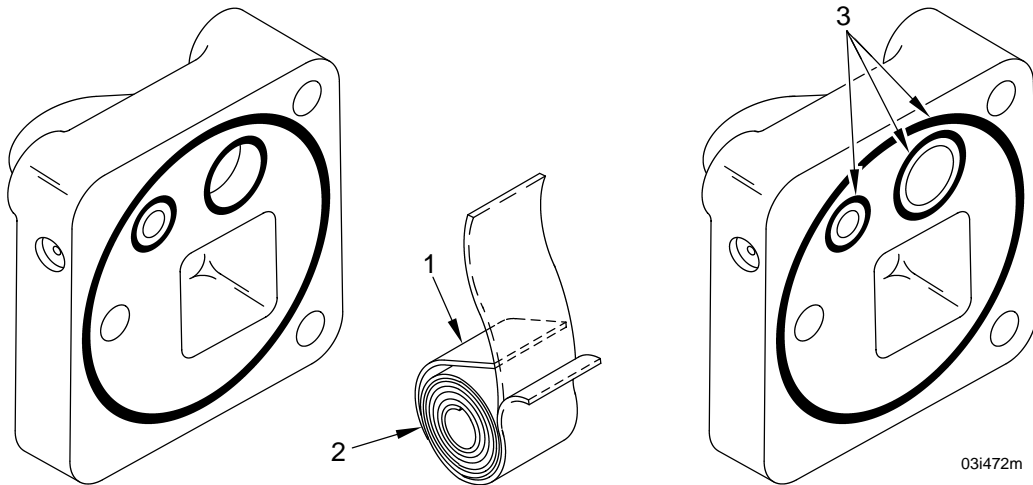
**11. Removal of Compressor Cover Inlet and Outlet Adapters and Preformed Packings.****NOTE**

This procedure applies to "clean air" turbo only.

- a. Remove compressor cover inlet adapter (1) and outlet adapter (2).
- b. Remove and discard two preformed packings (3).

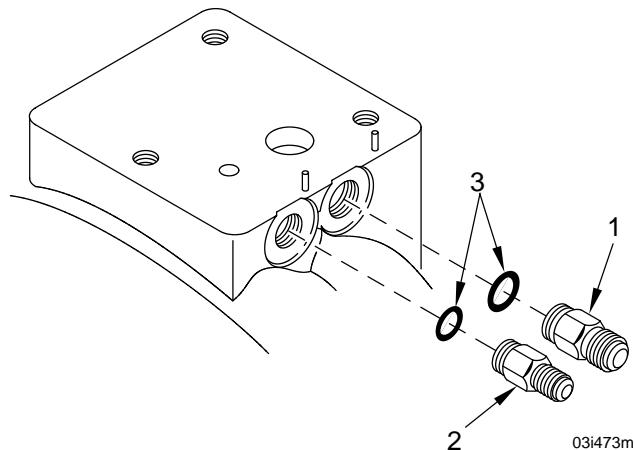
**END OF WORK PACKAGE**

CLEANING OF COMPONENT PARTS

0009 00**THIS WORK PACKAGE COVERS:**Cleaning

INITIAL SETUP:**Tools and Special Tools**

Hard bristle brush (item 5, WP 0016 00)
Plastic scraper (item 8, WP 0016 00)
Goggles (item 6, WP 0016 00)
Rubber gloves (item 7, WP 0016 00)

Materials/Parts

Solvent (item 3, WP 0016 00)
Rags, wiping, cotton (item 1, WP 0016 00)

Equipment Condition

Turbo components on workbench

NOTE

After disassembly and before inspection, all component parts must be thoroughly cleaned according to the following procedure.

CLEANING**WARNING**

Cleaning solvent is flammable! Use only in well ventilated areas. Keep away from flame, sparks, or heat. Avoid contact with eyes, and wear rubber gloves to prevent skin irritation.

1. Immerse metal parts in solvent and clean with bristle brush and plastic scraper. Use clean cloth moistened with solvent to clean hard to reach areas.

WARNING

Line pressure for compressed air used for cleaning shall not exceed 30 psi. Wear appropriate eye protection and gloves. Never direct the compressed air at another person.

CAUTION

Never use caustic solution, wire brush, or steel blade scraper.

2. Clean all drilled passages with wire probe and compressed air.
3. Make certain all housing surfaces surrounding the turbine and compressor wheels are clean and smooth.
4. Blow all parts dry with compressed air.

END OF WORK PACKAGE

INSPECTION OF COMPONENT PARTS

0010 00**THIS WORK PACKAGE COVERS:**

Inspection

INITIAL SETUP:**Tools and Special Tools**

General mechanic's tool kit (item 1, WP 0017 00)
Magnifier (item 3, WP 0017 00)
Gage, turbocharger (special tool) (Fig 4, item 1,
WP 0015 00)
Micrometer, outside (item 4, WP 0017 00)
Micrometer, outside (item 5, WP 0017 00)
Micrometer, outside (item 6, WP 0017 00)
Telescope gage set (item 7, WP 0017 00)

Equipment Condition

Turbo components on work bench; cleaned and dried

NOTE

All components not discarded during disassembly must be thoroughly inspected according to the following procedures to determine if they can be reused in rebuilding the turbo.

Some defects you may discover during inspection can be repaired (WP 0011 00); however, parts that are worn or damaged beyond repair must be replaced with new parts.

Wear standards for turbo components are provided within the applicable inspection procedures. Use appropriate precision measuring instruments when checking for wear. When measuring inside or outside diameters, always take two measurements approximately 90 degrees apart to allow for possible out-of-round condition.

When inspecting for cracks, use a strong light and magnifying glass.

INSPECTION OF COMPONENT PARTS - CONTINUED**0010 00****INSPECTION**1. Inspection of the Compressor Cover.

- a. Inspect compressor cover (1) for cracks.
- b. Inspect mounting flanges (2) and (3) for distortion or warping.
- c. Check for loose, missing, broken or damaged studs (4). Inspect threaded inserts (5) for damaged threads.
- d. Inspect mating surfaces for nicks, raised metal, or other damage.
- e. Replace compressor cover if cracked, or if mounting flanges are distorted.

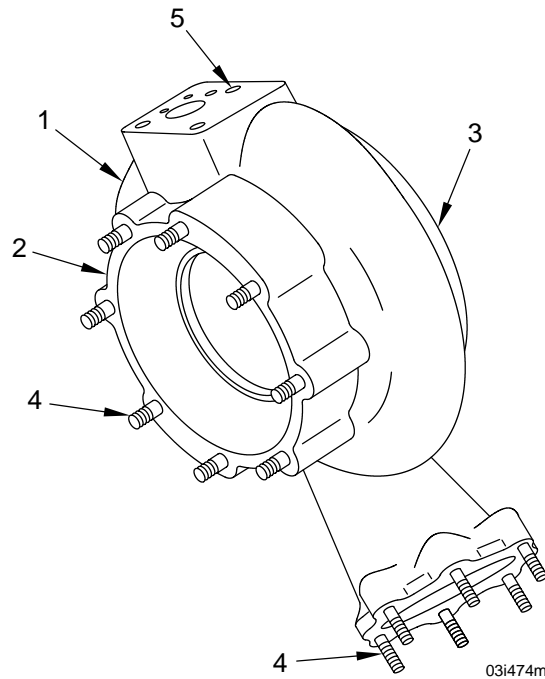
2. Inspection of the Compressor Wheel.**CAUTION**

It is important to use extra care when checking for cracked blades. If undetected, they could break during operation and cause severe damage.

- a. Inspect compressor wheel (1) for bent, cracked, broken or missing blades. Check back of wheel for evidence of rubbing against bearing housing.
- b. Check inside diameter of compressor wheel bore (2) using telescope gage and micrometer. The bore measurement must be greater than 0.500 inch but less than 0.5003 inch.
- c. Replace a damaged compressor wheel, or if the bore measures greater than 0.5003 inch.

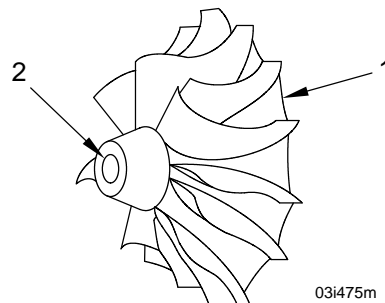

INSPECTION OF COMPONENT PARTS - CONTINUED**0010 00****3. Inspection of Turbine Wheel and Shaft Assembly.****CAUTION**

It is important to use extra care when checking for cracked blades. If undetected, they could break during operation and cause severe damage.

- a. Inspect turbine wheel and shaft assembly (1) for bent, cracked, broken, or missing blades, or a bent shaft.
- b. Using micrometer, check the diameter of the thrust area (2) of the shaft. The measurement must be from 0.5000 inch to 0.4997 inch.
- c. Using micrometer, check the length of the shaft (3) from thrust surface shoulder to inner face of turbine wheel. This measurement must be from 3.9860 inches to 3.9820 inches.
- d. Using micrometer, check the diameter of the bearing area of the shaft (4). This measurement must be from 0.6865 inch to 0.6862 inch.
- e. Inspect metal seal ring groove (5) for wear using gage (6). If "NO-GO" end of gage enters the ring groove, replace the turbine wheel end shaft assembly.
- f. Replace the turbine wheel and shaft assembly if damaged or if it does not meet the wear standards specified in the preceding steps.

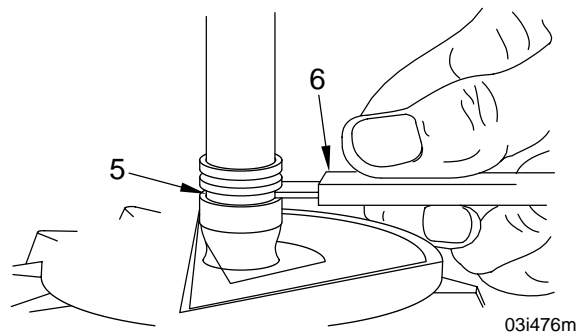
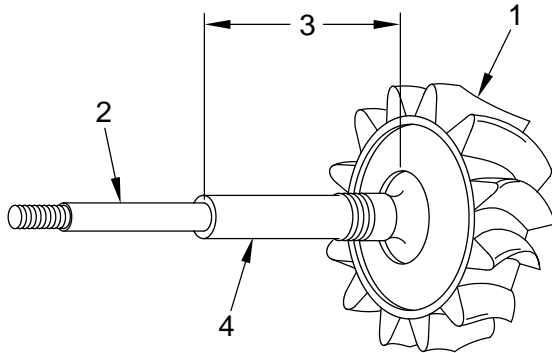

03i476m

INSPECTION OF COMPONENT PARTS - CONTINUED**0010 00****4. Inspection of the Bearing Housing.**

- a. Inspect the bearing housing (1) for cracks, damage, or scoring of the bore. Ensure the oil drain port (2) is clear and all residue build-up has been completely removed.
- b. Check for warping or distortion of the mounting flanges and mating surfaces.
- c. Using telescope gage and micrometer, check inside diameter of bore (3). This measurement must be from 1.0628 inches to 1.0633 inches.
- d. Replace the bearing housing if it is cracked or otherwise damaged, if the bore is badly scored, if there are any bronze deposits in the bore, or if it does not meet the wear standards.

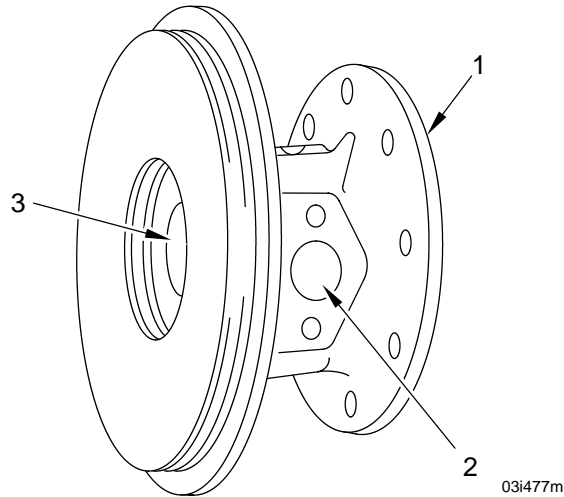
**5. Inspection of the Oil Deflector.**

- a. Inspect the oil deflector (4) for cracks, distortion, or other damage, especially in the thrust ring area.
- b. Replace a damaged oil deflector.

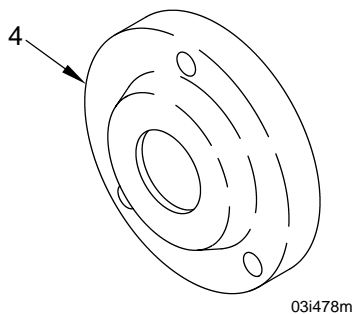

INSPECTION OF COMPONENT PARTS - CONTINUED**0010 00****6. Inspection of the Turbine Housing.**

- a. Inspect the turbine housing (1) for cracks or distorted mounting flanges (2), (3), and (4). Inspect the condition of threaded holes (5) and studs (6).

NOTE

Minor cracks in the exhaust outlet flange (3) are not cause for discarding the part.

- b. Check the inside surface of the housing (7) for evidence of contact with turbine wheel.
- c. Replace the turbine housing if cracked, or if mounting flanges are distorted.

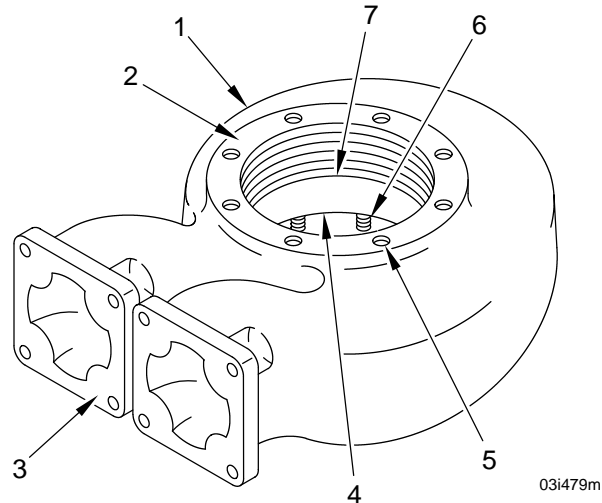
**7. Inspection of the Turbine Backplate.**

- a. Inspect turbine backplate (1) for cracks, distortion, warpage, or other damage.
- b. Replace a damaged turbine backplate.

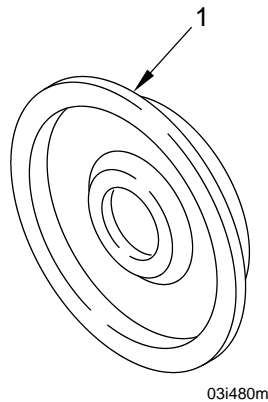

INSPECTION OF COMPONENT PARTS - CONTINUED

0010 00

8. Inspection of the Clamp.

- a. Inspect clamp (1) for cracks or separated welds.
- b. Inspect nut (2) and stud (3) for thread damage.
- c. Replace damaged clamp or nut.

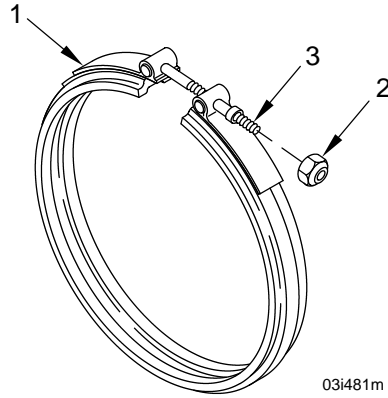

9. Inspection of the Mounting Legs and Oil Drain Tube.

- a. Inspect mounting legs (1) for cracks.
- b. Inspect oil drain tube (2) for cracks, bends, or crushed condition.
- c. Replace damaged mounting legs or oil drain tube.

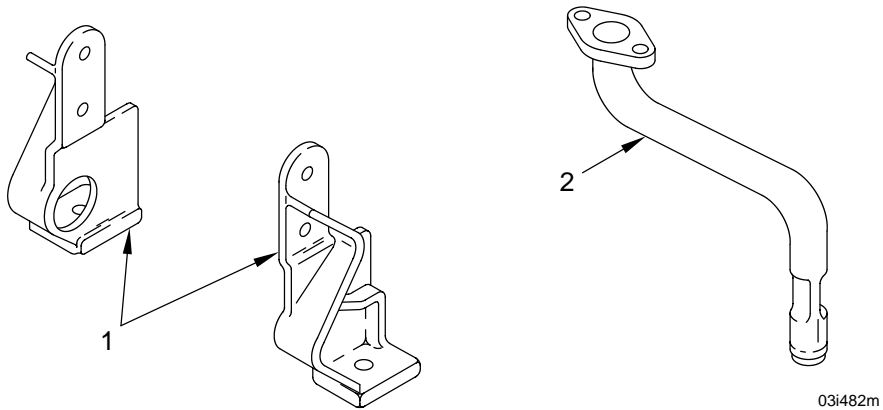

10. Inspection of the Shield.

- a. Inspect shield (1) for cracks or deformation.
- b. Replace cracked shield.

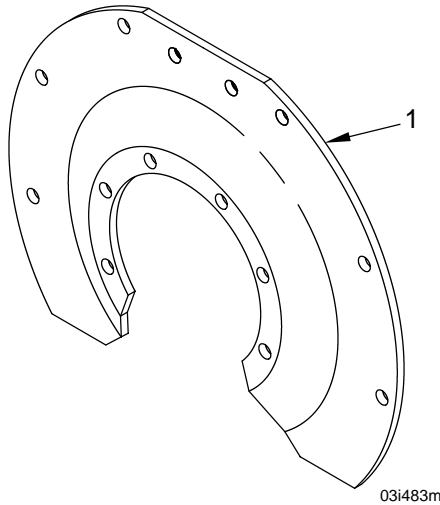

11. Inspection of Dust Detector Cover, Inlet and Outlet Adapters and Filter Retaining Strap.

NOTE

This procedure applies to "clean air" turbo only.

- a. Inspect dust detector cover (1) for cracks, scoring of mating surface (2), and thread damage in tapped holes (3).
- b. Check adapters (4) and (5) for cracks, distortion, or thread damage. Ensure both are clear of obstruction.
- c. Inspect filter retaining straps (6) for cracks, bends, and general serviceability.
- d. Verify presence of pipe plug (7).
- e. Replace any of these components if damaged.

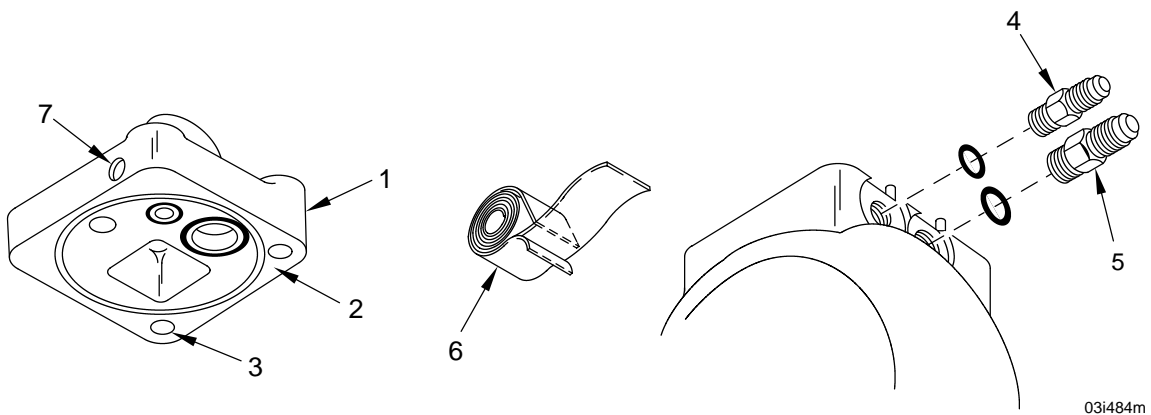

END OF WORK PACKAGE

REPAIR OF COMPONENT PARTS

0011 00**THIS WORK PACKAGE COVERS:**

Repair

INITIAL SETUP:**Tools and Special Tools**

General mechanic's tool kit (item 1, WP 0017 00)
1/4 to 3/4 inch diameter, 1/2 inch drive, stud remover
and setter
Thread taps (Fig 4, item 6, WP 0015 00)
Screw thread inserter (Fig 4, item 5, WP 0015 00)

Equipment Condition

Turbo components on workbench; cleaned and
inspected

Materials/Parts

Screw thread inserts, MS2120865-20 (WP 0015 00) -
MODEL 5HDR
Studs, C157631 (WP 0015 00)
Studs, C157415 (WP 0015 00)
Screw thread inserts, MS122162 (WP 0015 00) -
MODEL 5HDR PART #18727 and 655595

NOTE

Repair of turbo components is, for the most part, limited to stud replacement and repair of tapped holes in the compressor cover and turbine housing. Slight nicks or raised metal on mating surfaces can be smoothed using a fine hand file. In all cases, if a component cannot be restored to its original condition, it must be replaced.

Use the procedures provided below for repair of turbo components.

REPAIR OF COMPONENT PARTS - CONTINUED**0011 00****REPAIR**1. Repair of the Compressor Cover.

- a. Smooth small nicks or raised metal using a fine hand file.
- b. Remove and discard loose or damaged studs using stud remover and setter.
- c. Drill a 21/64 inch (8.33 mm) hole to a depth of 7/8 inch (22.2 mm).
- d. Tap a 5/16-18 thread using special heli-coil thread tap.
- e. Install screw thread insert, part number MS21208C5-20, into threaded guide of screw thread inserter by slowly turning the pilot counterclockwise until the insert is flush with the end of the inserter. Insert the pilot of the inserter into the tapped hole, with the face of the inserter resting solidly against the compressor housing. Slowly turn the pilot handle clockwise until no further resistance is felt. Remove inserter.
- f. Using stud remover and setter, install coarse thread end of the new stud, part number C157631, to a setting height of 13/16 inch (20.64 mm).

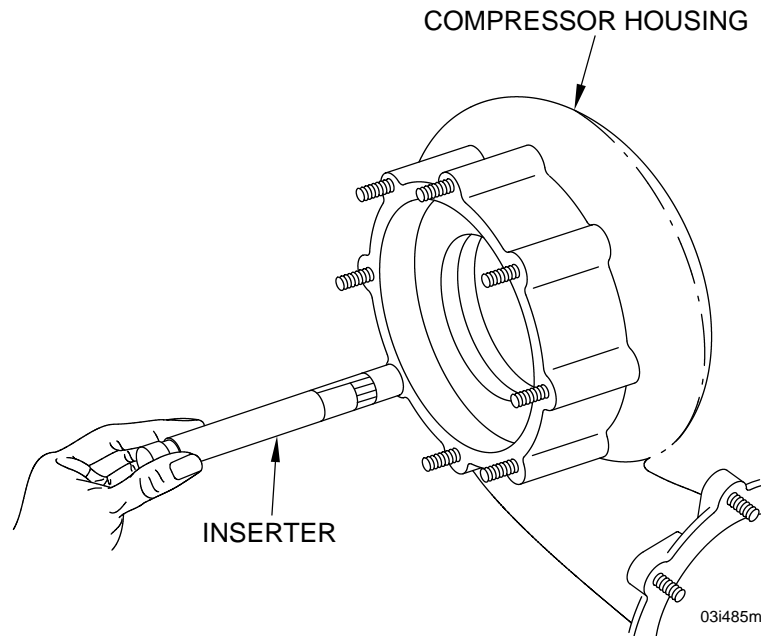

REPAIR OF COMPONENT PARTS - CONTINUED**0011 00**2. Repair of the Turbine Housing.

- a. Smooth small nicks or raised metal using a fine hand file.
- b. Remove and discard loose or damaged studs (1) using stud remover and setter.
- c. Using stud remover and setter, install coarse thread end of new stud, part number C157415, to a setting height of 1.00 inch (25.4 mm).
- d. Repair damaged threads using a 3/8-16NC thread tap.

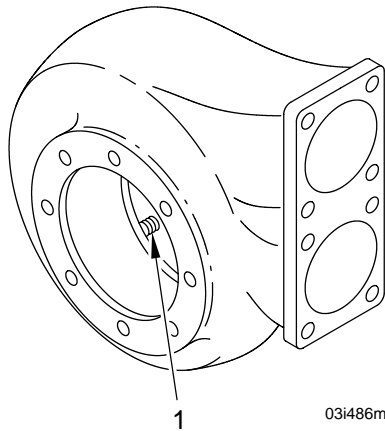
3. Repair of the Oil Drain Tube and Shield.

Minor bends in the oil drain tube and shield can be straightened as long as the integrity of the part remains intact.

4. Repair of the Bearing Housing, Mounting Legs, and Turbine Backplate.

Slight nicks on the mating surfaces of these components can be smoothed using a hand file. Re-tap threaded holes, if damaged.

END OF WORK PACKAGE

ASSEMBLY AND OPERATIONAL TESTING

0012 00**THIS WORK PACKAGE COVERS:**Assembly and Operational Testing

INITIAL SETUP:**Tools and Special Tools**

General mechanic's tool kit (item 1, WP 0017 00)
Installing sleeve (Fig 4, item 3, WP 0015 00)
Retaining ring pliers (Fig 4, item 2, WP 0015 00)
Box end wrench (special tool) (Fig 4, item 4,
WP 0015 00)
5/8 inch, 1/2 inch drive deep well socket (item 8,
WP 0017 00)
9/16 inch, 1/2 inch drive deep well socket (item 9,
WP 0017 00)
Feeler gages (item 10, WP 0017 00)
3/8 inch crowfoot attachment (item 11, WP 0017 00)

Materials/Parts

Oil drain tube gasket (Figs 2 and 3, item 54, WP
0015 00)

Equipment Condition

Turbo components on work bench; cleaned, inspected
and repaired

NOTE

Assemble the turbo according to the following procedures. Use special care to ensure the cleanliness of each part. Coat each part with a light film of engine oil (OE/HDO) immediately before installation.

All parts discarded during disassembly are replaced with new parts during assembly. Requisition turbosupercharger parts kit, part number 5705073. Refer to WP 0015 00. All kit parts listed in the Repair Parts and Special Tools List for your configuration of turbo ("clean air" or standard) must be used during assembly.

ASSEMBLY

1. Installation of Metal Seal Rings on Turbine Wheel and Shaft Assembly and Flinger Sleeve.
 - a. Place installing sleeve (1) over turbine wheel and shaft assembly (2).
 - b. Install new metal seal ring (3) by sliding over installing sleeve into ring groove (4).
 - c. Remove ring installing sleeve.
 - d. Place installing sleeve over new flinger sleeve (5).
 - e. Install two new metal seal rings (6) by sliding over installing sleeve into ring groove (7).
 - f. Remove installing sleeve.

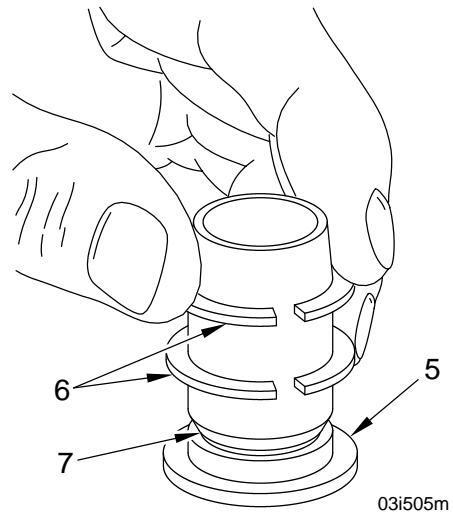
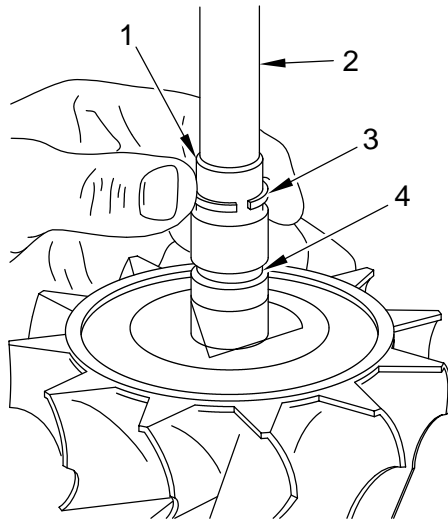

2. Installation of Thrust Washer Bearing, Lower Sleeve Bearing, Retaining Rings, and Upper Sleeve Bearing.

- a. Place bearing housing (1) on work bench with larger flange up.

NOTE

If the third (bottom) retaining ring was removed from the bore of bearing housing during disassembly, it must be installed using retaining ring pliers before the following steps can be performed.

- b. Install new thrust washer bearing (2) and new lower sleeve bearing (3).

CAUTION

Use care when installing retaining rings that they do not scratch the bore of the bearing housing.

NOTE

Retaining rings have one rounded side and one flat side. Install retaining rings with rounded sides toward sleeve bearings.

- c. Using retaining ring pliers, install two retaining rings (4) in grooves in bearing housing bore.

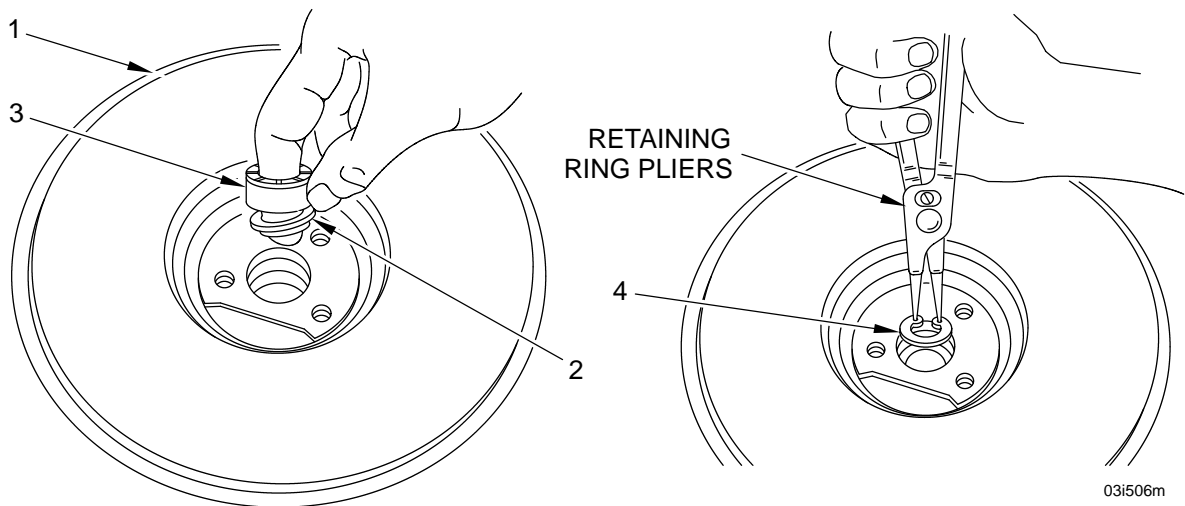

- d. Install upper sleeve bearing (5).

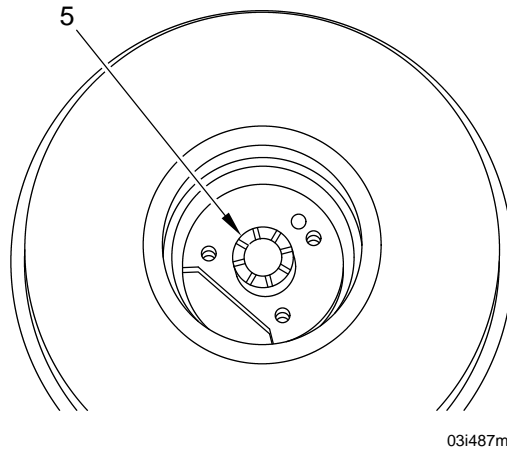

3. Installation of Turbine Backplate and Turbine Wheel and Shaft Assembly.

- a. Position turbine backplate (1) on turbine wheel and shaft assembly (2).

CAUTION

Use steady pressure, but do not force the shaft into the bore of the bearing housing. The new metal seal ring may be fractured.

- b. Install turbine wheel and shaft assembly into backplate in bearing housing by inserting the shaft into the bore and, using a rocking motion, working the metal seal ring into the bore as far as possible.

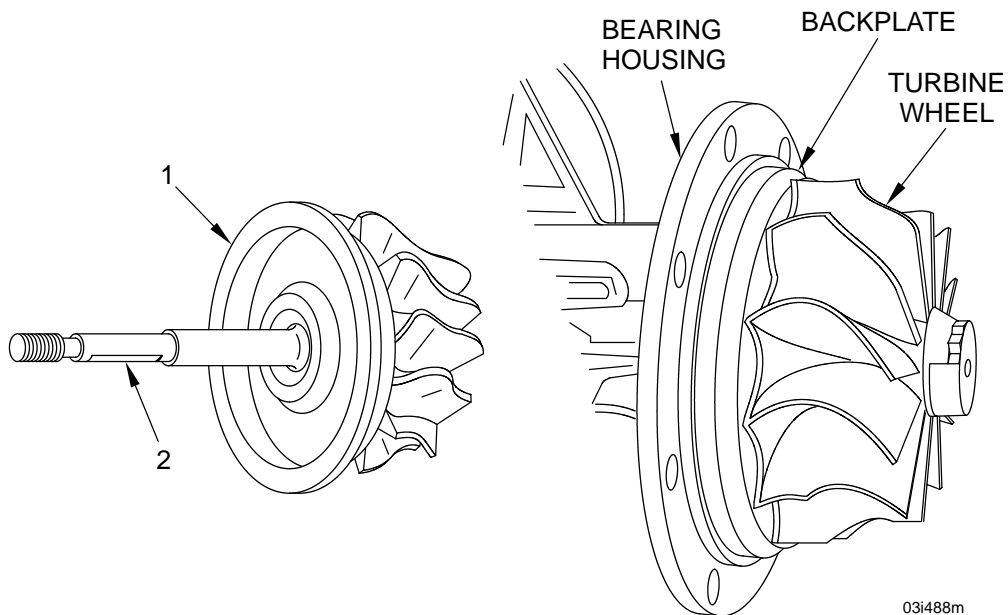

ASSEMBLY AND OPERATIONAL TESTING - CONTINUED**0012 00**

4. Installation of Spacer, Lower Thrust Ring, Thrust Sleeve Bearing, Thrust Bearing, and Upper Thrust Ring.
- Hold assembled turbine wheel and shaft assembly, turbine backplate, and bearing housing (1) in upright position (large flange up).
 - Install new spacer (2). Ensure screw holes are properly aligned.
 - Install new lower thrust ring (3).
 - Install new thrust sleeve bearing (4).

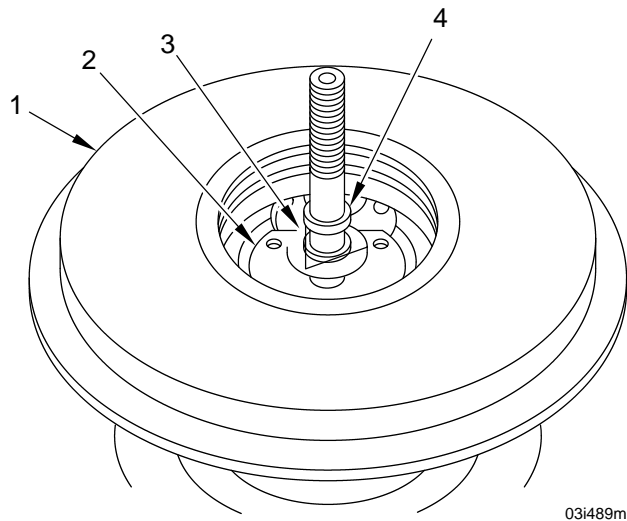

- Install new thrust bearing (5). Ensure screw holes are aligned properly.
- Install new upper thrust ring (6).

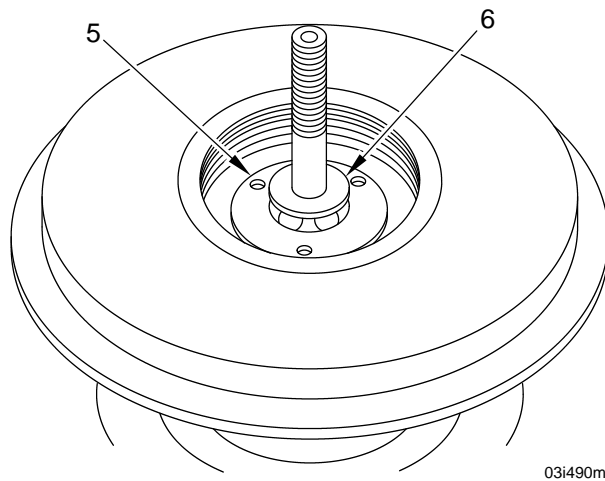

5. Installation of Oil Deflector, Flinger Sleeve with Metal Seal Rings and Preformed Packing.

- a. Install oil deflector (1) and align screw holes.
- b. Install three new oil deflector screws (2). Torque screws to 55 to 65 lb-in (6.215 to 7.345 N•m).

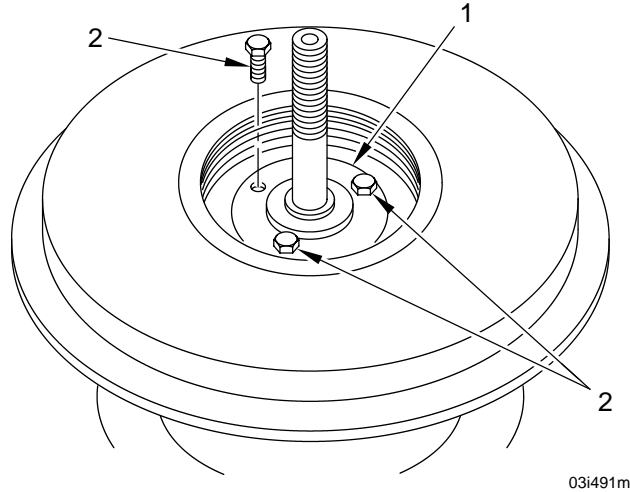

03i491m

- c. Install new flinger sleeve (3) with two new metal seal rings (4).
- d. Install new preformed packing (5) in bearing housing groove.

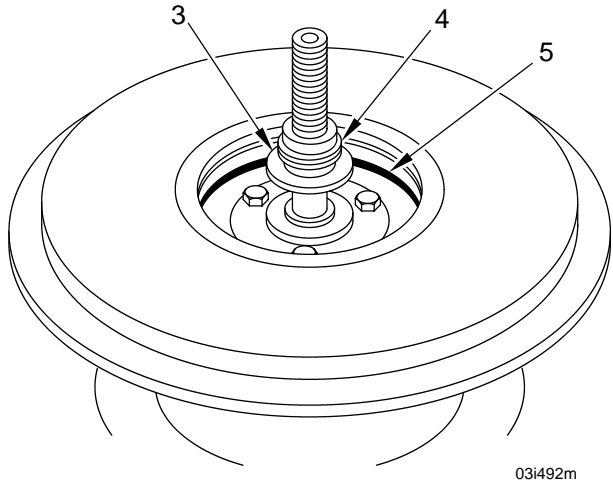

03i492m

6. Installation of Flinger Sleeve Insert, Retaining Ring, Compressor Wheel Shims, and Compressor Wheel.

CAUTION

Use steady pressure but do not force flinger sleeve insert into bearing housing; metal seal rings or flinger sleeve may fracture.

- a. Center metal seal rings (1) on flinger sleeve (2) with gaps in rings 90 degrees apart.
- b. Install flinger sleeve insert (3) in bearing housing below retaining ring groove. The arrow (4) stamped on the top of the insert should be in line with the oil inlet port of the bearing housing.
- c. Install retaining ring (5).
- d. Install compressor wheel shims (6).

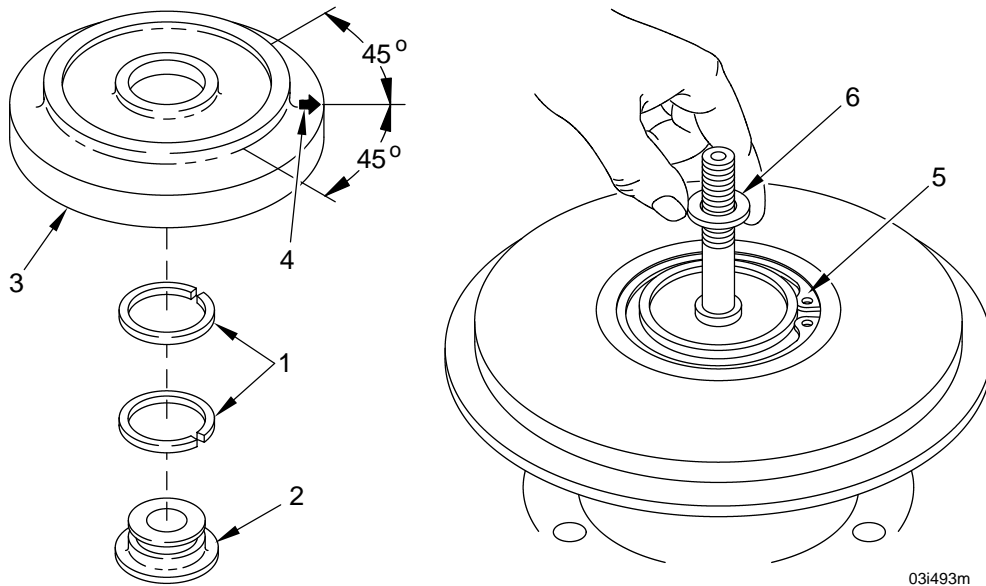

- e. Place a 1-1/8 inch angular 12 point box wrench (7) in a vise. Position wrench to hold turbine wheel hub.

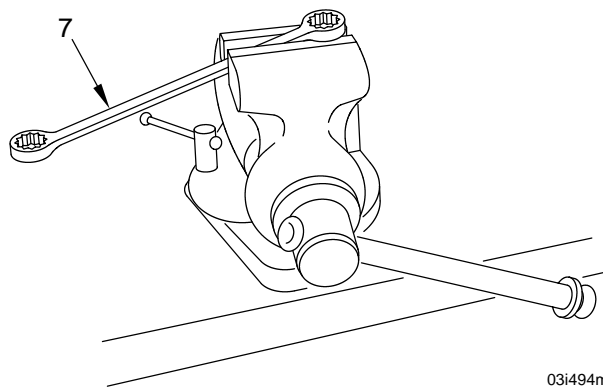

ASSEMBLY AND OPERATIONAL TESTING - CONTINUED**0012 00**

- f. While supporting turbine wheel and shaft assembly in the bearing housing, place turbine wheel hub in box wrench. Hold in position.
- g. Install compressor wheel (8) on shaft.
- h. Install new compressor wheel lock nut (9). Torque lock nut to 50 to 55 lb-ft (67.8 to 74.6 N•m).
- i. Remove unit from vise.

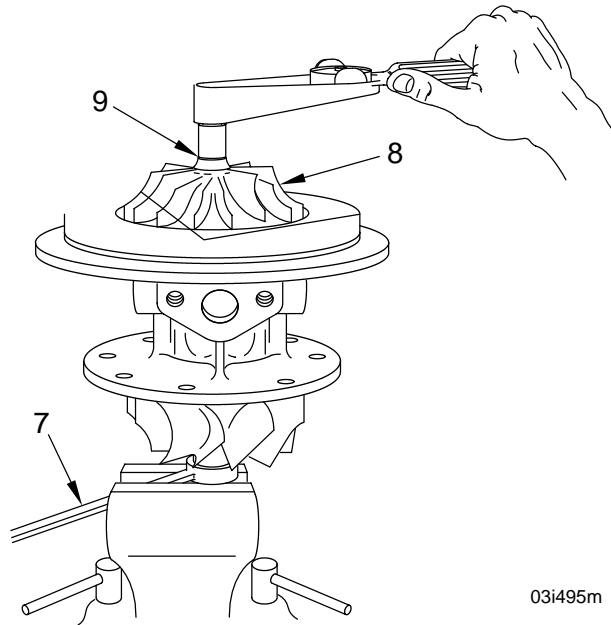

03i495m

7. Check Compressor Wheel Back Clearance.

- a. With compressor wheel lock nut (1) tightened to 50 to 55 lb-ft (67.8 to 74.6 N•m), check the clearance between compressor wheel (2) and bearing housing (3) using feeler gages (4).
- b. Clearance must be from 0.019 to 0.022 inch. Add or remove compressor wheel shims as required to obtain proper clearance.

NOTE

Compressor wheel shims are available in 0.003, 0.005, and 0.010 inch thicknesses.

8. Installation of Turbine Housing, Shield, Preformed Packing and Compressor Cover.**NOTE**

Table 3-1 provides information for proper indexing of the turbine housing and compressor cover according to engine model and mounting location. Table 3-1 applies to both "clean air" and standard turbosuperchargers.

- a. Place turbine housing (5) on studs.
- b. Install bearing housing with compressor and turbine wheels (6) in turbine housing.
- c. Align marks (7) scribed in housing flanges during disassembly. If alignment marks cannot be located, or if either housing has been replaced, refer to Table 3-1 to determine proper housing positions.

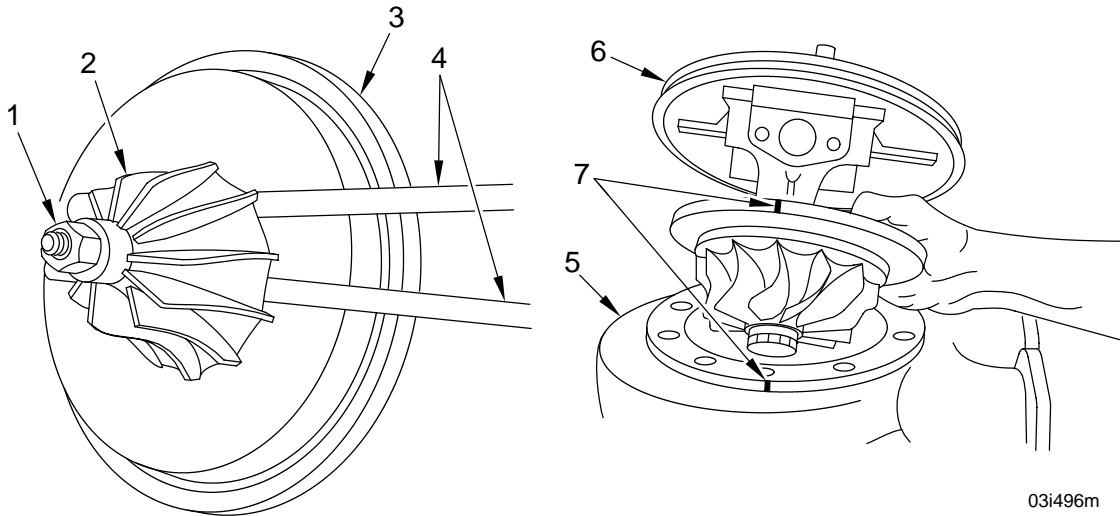

03i496m

Table 3-1. Housing alignment.

Engine Models AVDS-1790-2DR, AVDS-1790-2C, AVDS-1790-2CA, AVDS-1790-2D, AVDS-1790-2DA and AVDS-1790-8CR.

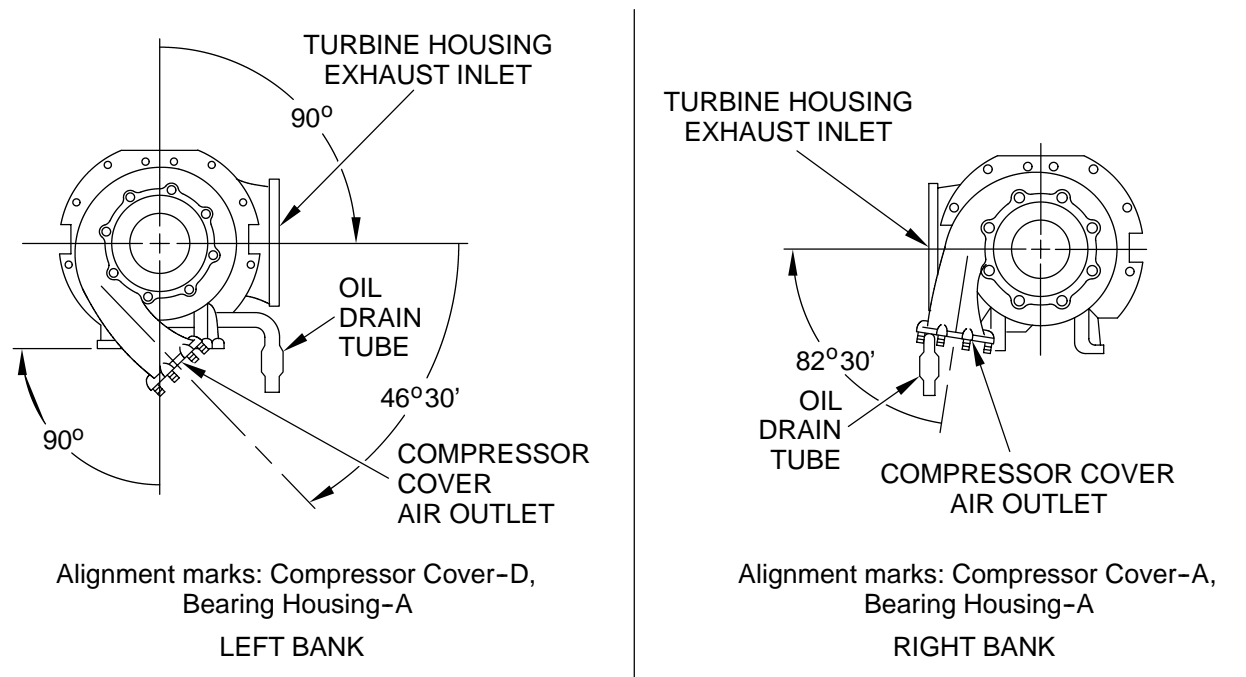

Engine Model AVDS-1790-2DR.

NOTE: External Shield not used.

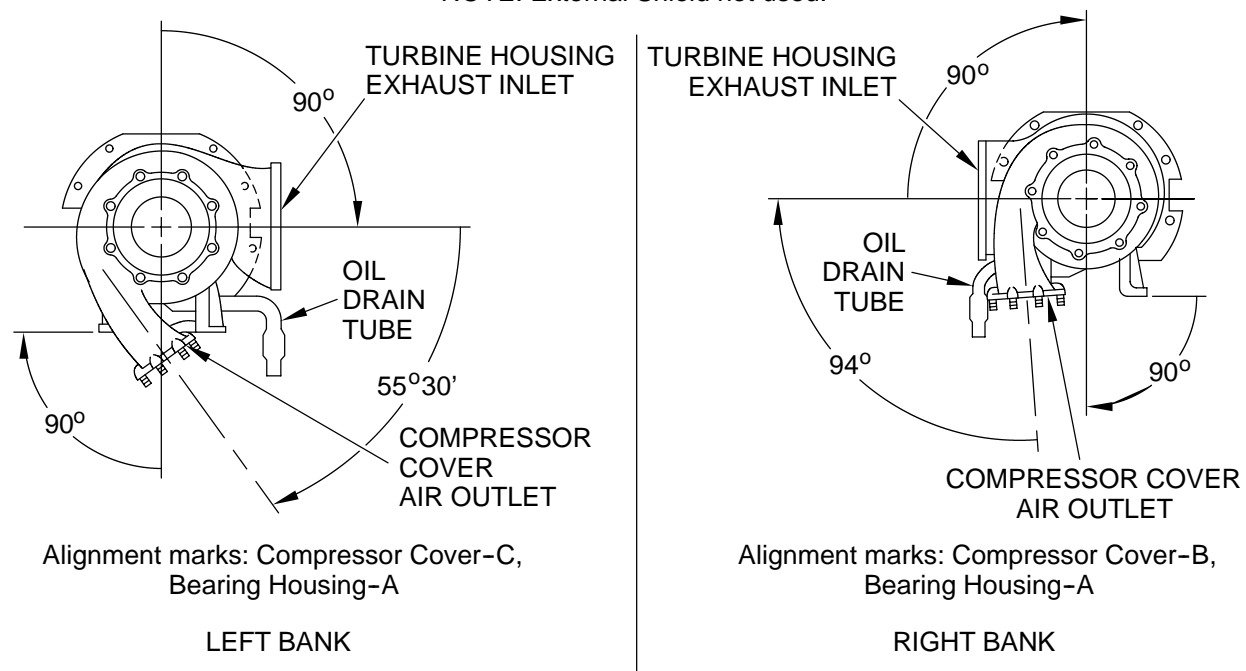

03i497m

- d. Install shield (8).

NOTE

If your turbo is to be used on engine models AVDS-1790-2DR the shield is not used.

- e. Install three new locking plates (9) and six cap screws (10). Do not install locking plate and two cap screws under oil drain tube boss (11).
- f. Torque cap screws to 230 to 250 lb-in (25.99 to 28.25 N•m).
- g. Install new locking plate and two cap screws under drain tube boss. Torque cap screws to 200 to 220 lb-in (22.6 to 24.86 N•m) using box wrench (12).

NOTE

The added length of the box wrench decreases the 240 lb-in value by approximately 30 lb-in.

- h. Bend locking plate tabs against flats on cap screws.
- i. Check end play (WP 0005 00-2). Total end play must be greater than 0.004 inch and less than 0.006 inch. If end play is not within these limits, disassemble turbo and recheck for worn parts. Reassemble turbo and recheck end play.

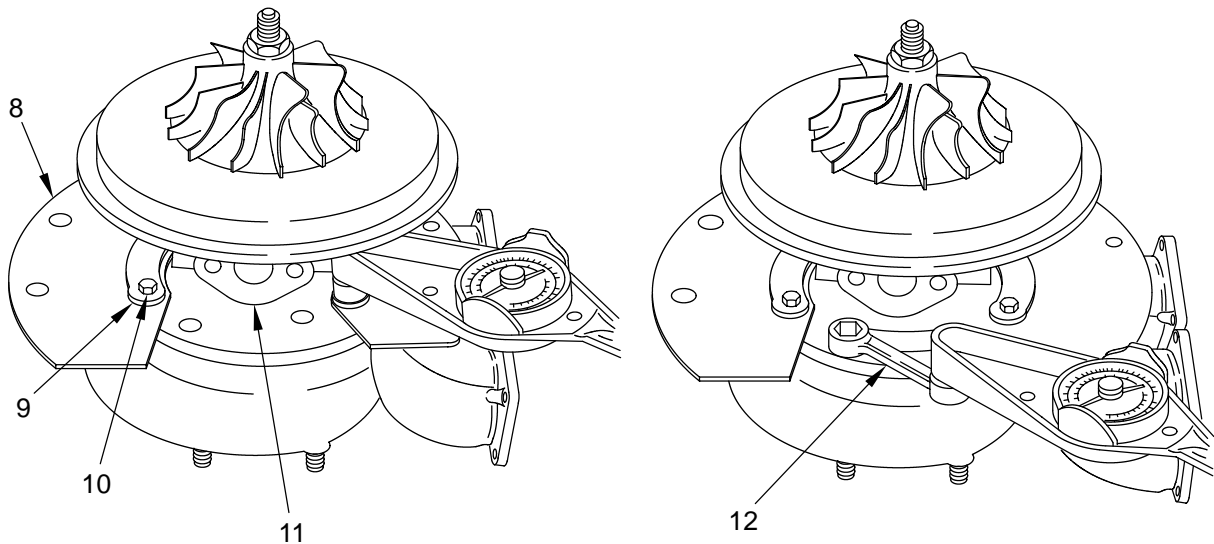

03i498m

ASSEMBLY AND OPERATIONAL TESTING - CONTINUED**0012 00**

- j. Install new preformed packing (13) on bearing housing.
- k. Install clamp (14) and slide it down on bearing housing.
- l. Install compressor cover (15). Align marks (16) scribed in housing flanges during disassembly. If your turbo is a new/newer model, alignment marks will be cast into the flanges of the compressor cover and housing, and the marks you noted during disassembly should be matched.

NOTE

If you cannot locate the alignment marks, or if you are otherwise unsure of the indexing of the housings for your turbo, consult Table 3-1.

- m. Place clamp (17) over compressor cover and bearing housing flanges, and install clamp nut (18).
- n. Torque clamp nut to 110 to 130 lb-in (12.43 to 14.69 N•m).

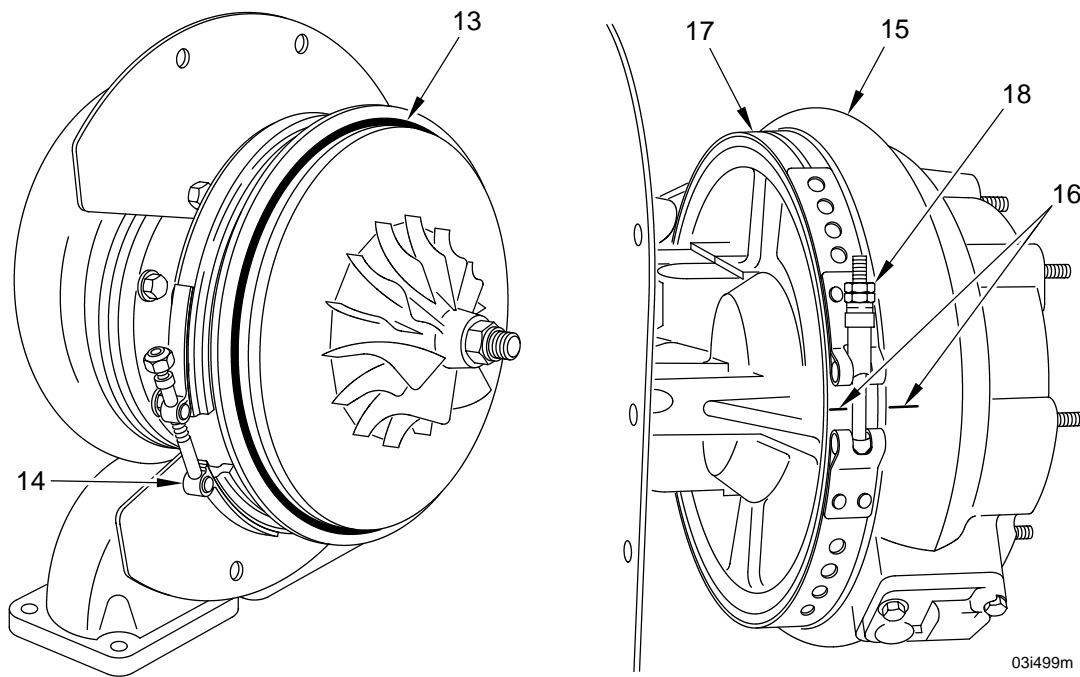

9. Installation of Mounting Legs and Oil Drain Tube.**NOTE**

The mounting leg on the same side as the turbine housing exhaust inlet is referred to as the "inner" mounting leg and must be installed first.

- a. Install inner mounting leg (1) and secure with two cap screws and new lockwashers (2).
- b. Torque cap screws to 230 to 250 lb-in (25.99 to 28.25 N•m).
- c. Install new gasket (3) and oil drain tube (4). Secure with two cap screws and new lockwashers (5).

NOTE

The oil drain tube must pass through the opening in the INNER leg. The oil drain tube must always be on the same side as the turbine housing exhaust inlet.

- d. Torque cap screws to 230 to 250 lb-in (25.99 to 28.25 N•m) using crowfoot attachment (6).

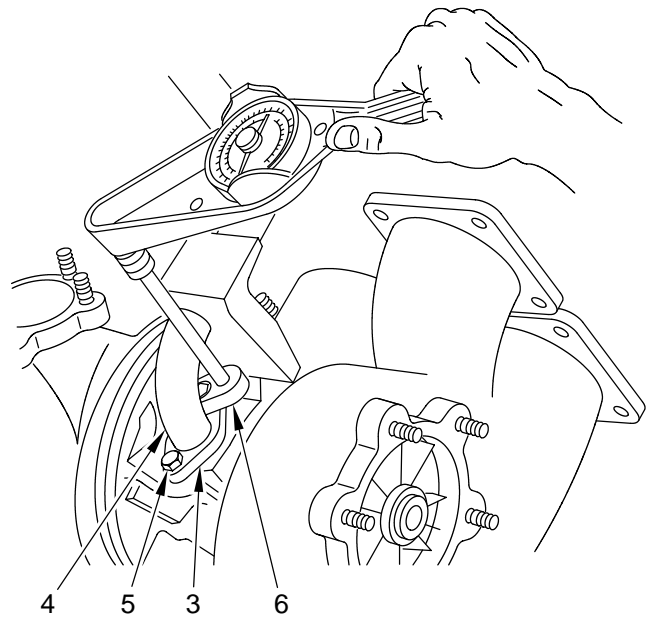
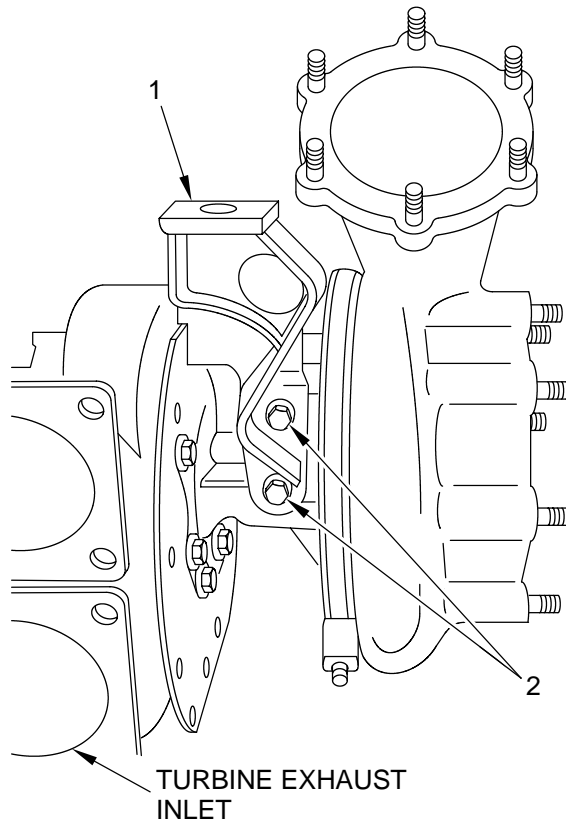

03i500m

- e. Install outer mounting leg (1) and secure with two cap screws and new lockwashers (2).
- f. Torque lockwashers to 230 to 250 lb-in (25.99 to 28.25 N•m).

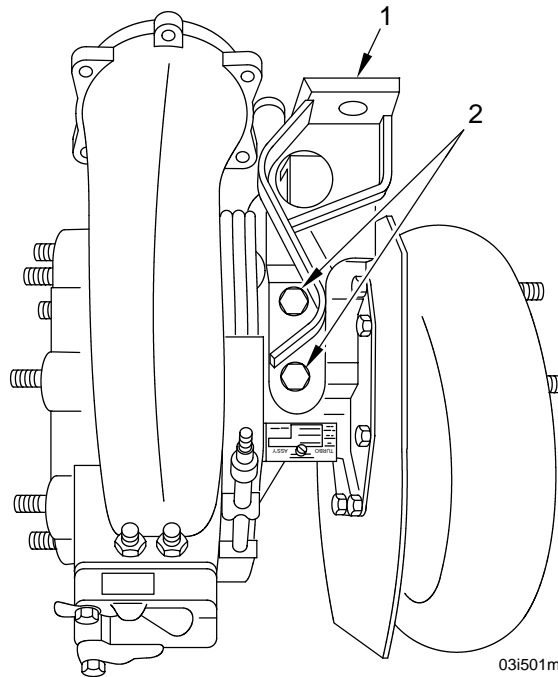

10. Installation of Compressor Cover Inlet and Outlet Adapters and Preformed Packings.

NOTE

This procedure applies to “clean air” turbo only.

- a. Install new preformed packings (1) and (2) on compressor cover inlet adapter (3) and outlet adapter (4).

NOTE

The inlet adapter is slightly larger than the outlet adapter and requires the larger preformed packing.

- b. Install adapters with preformed packings in compressor cover (5).
- c. Using deep well sockets, torque adapters to 55 to 65 lb-in (6.215 to 7.345 N•m).

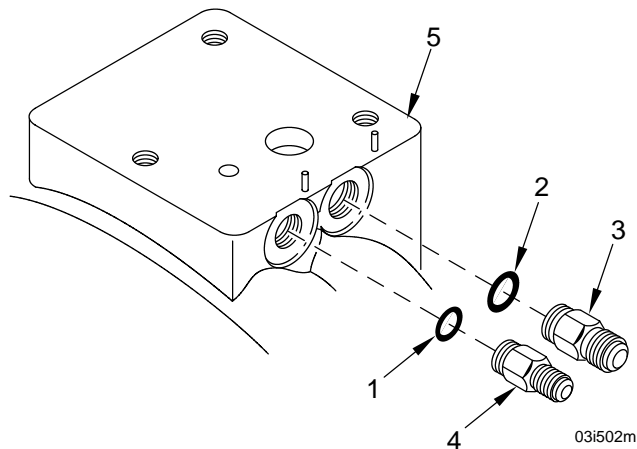

11. Installation of Preformed Packings, Filter Retaining Strap, and Filter in Dust Detector Cover.**NOTE**

This procedure applies to "clean air" turbo only.

- a. Install three new preformed packings (1) in grooves in underside of dust detector cover (2).
- b. Assemble filter retaining strap (3) and filter (4), and install in recess in underside of dust detector cover.

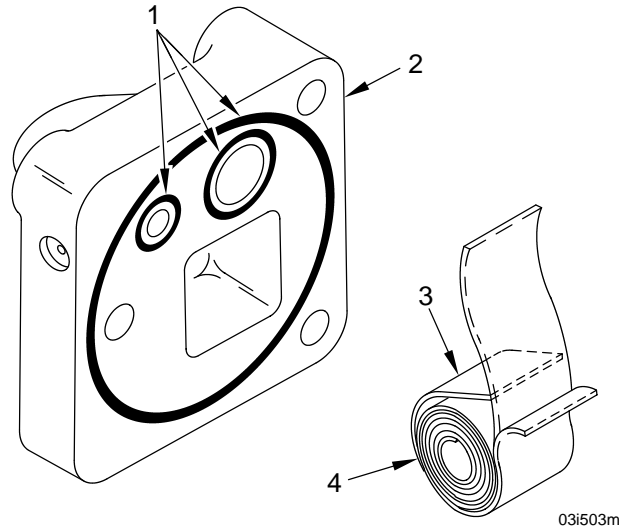

12. Installation of Dust Detector Cover, Packing with Retainer, Chain Fastener, Chain "S" Hook, and Chain.**NOTE**

This procedure applies to "clean air" turbos only.

- a. Position dust detector cover (1) on compressor cover (2). Ensure mounting holes are properly aligned.
- b. Install new packing with retainer (3) on cap screw (4).
- c. Install assembled chain fastener (5), "S" hook (6), and chain (7) on cap screw and lockwasher (8).
- d. Secure dust detector cover (1) to compressor cover (2) with attaching hardware.

NOTE

Ensure the longer cap screw (9) is installed in the position shown.

- e. Torque tighten cap screws to 110 to 130 lb-in (12.43 to 14.69 N•m).

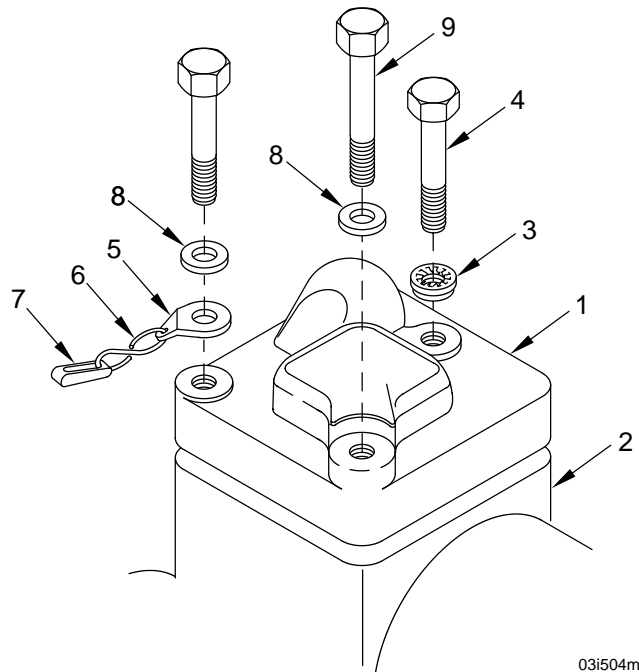

03i504m

OPERATIONAL TESTING**1. Operational Testing of the Turbo.**

Since turbosupercharger performance depends on engine performance, the turbosupercharger cannot be tested unless it is installed on an engine. Therefore, testing a turbo not mounted on an engine consists only of ensuring free rotation of the turbine wheel and shaft assembly and checking radial movement and end play (WP 0005 00). If the turbo passes these tests, it is approved for installation on an engine.

END OF WORK PACKAGE

PRESERVATION AND STORAGE**0013 00****THIS WORK PACKAGE COVERS:**

Preservation and Storage

INITIAL SETUP:**Tools and Special Tools**

General mechanic's tool kit (item 1, WP 0017 00)

Equipment Condition

Completely assembled turbo on workbench

Materials/Parts

Lubricant (item 2, WP 0016 00)

Tape (item 4, WP 0016 00)

Lubricating oil, general (item 9, WP 0016 00)

Barrier material (item 10, WP 0016 00)

Paperboard wrapping and cushioning (item 11, WP 0016 00)

Tape, pressure sensitive adhesive (item 12, WP 0016 00)

Tape, pressure sensitive adhesive (item 13, WP 0016 00)

Sleeve, interior packing (item 14, WP 0016 00)

References

ASTM D 5118

PRESERVATION AND STORAGE1. Short Term Storage.

- a. Fill turbosupercharger bearing housing with preservative general purpose lubrication oil (item 9, WP 0016 00). Apply a light coat of the same oil to the exterior surface. Remove excess oil.
- b. Wrap turbosupercharger with waterproof, greaseproof barrier material (item 10, WP 0016 00).
- c. Wrap turbosupercharger in wrapping and cushioning paperboard (item 11, WP 0016 00).
- d. Tape securely with paper packing/masking tape (item 12, WP 0016 00).
- e. Place package in a carton made from fiberboard shipping box material (per ASTM D 5118 guidelines).
- f. Tape carton securely with waterproof packaging tape (item 13, WP 0016 00).

2. Long Term Storage.

- a. Preserve and package turbosupercharger as outlined above.
- b. Place carton in interior packaging sleeve and tubing bag (item 14, WP 0016 00). Seal bag using standard heat sealing equipment.
- c. Place sealed bag in a carton made from fiberboard shipping box material (per ASTM D 5118 guidelines).
- d. Tape carton securely with waterproof packaging tape (item 13, WP 0016 00).

ASTM D 5118 Guidelines.

- Style RSC = regular slotted box
- Type CF = corrugated fiberboard
- Grade 125 = size and weight limits
- Class DOM = domestic

END OF WORK PACKAGE

CHAPTER 4

SUPPORTING INFORMATION

REFERENCE WORK PACKAGE

0014 00

THIS WORK PACKAGE COVERS:

Scope, Standard Forms, Technical Manuals, Supply Catalogs, Specifications and Standards, and Publication Indexes

SCOPE

This work package lists all field manuals, forms, technical manuals and miscellaneous publications referenced in this manual.

STANDARD FORMS

- First Aid FM 4-25.11
- Product Quality Deficiency Report (NSN 7540-00-133-5541) (This item is included on EM 0001) SF Form 368
- Recommended Changes to Publications and Blank Forms (This item is included on EM 0001) DA Form 2028

TECHNICAL MANUALS

- Direct Support and General Support Maintenance Manual for Engine, W/Container: Turbosupercharged, Diesel, Fuel Injection, 90 Degree, V-Type, Air-Cooled, 12-Cylinder Assembly; Models AVDS-1790-2C (NSN 2815-00-410-1203), AVDS-1790-2D (2815-00-410-1204), AVDS-1790-2DR (2815-00-124-5387), AVDS-1790-2CA (2815-01-149-1353) and AVDS 1790-2DA (2815-01-166-2051) (Reprinted W/Basic Incl C1-5) (This item is included on EM 0036, EM 0044 and EM 0063) TM 9-2815-220-34
- Direct Support and General Support Maintenance Repair Parts and Special Tools List (Including Depot Maintenance Repair Parts and Special Tools) for Engine With Container; Turbosupercharged, Diesel, Fuel Injection, 90 Degree, V-Type, Air-Cooled, 12-Cylinder Assembly; Models AVDS-1790-2DR (NSN 2815-00-124-5387), AVDS-1790-2CA (2815-01-149-1353), and AVDS-1790-2DA (2815-01-166-2051) (This item is included on EM 0036, EM 0044 and EM 0063) TM 9-2815-220-34P
- Materials Used for Cleaning, Preserving, Abrading and Cementing Ordnance Materiel and Related Materiels Including Chemicals TM 9-247
- Operator's Manual: Operator Controls and PMCS for Tank, Combat, Full-Tracked: 105-MM Gun, M60A1 (NSN 2350-00-756-8497) and M60A1 (AOS) (2350-01-058-9487) (Reprinted W/Basic Incl C1-5) TM 9-2350-215-10-1
- Operator's Manual: Operation Under Usual and Unusual Conditions for Tank, Combat, Full-Tracked: 105-MM Gun, M60A1 (NSN 2350-00-756-8497) and M60A1 (AOS) (2350-01-058-9487) (Reprinted W/Basic Incl C1) TM 9-2350-215-10-2
- Operator's Manual: Troubleshooting and Maintenance for Tank, Combat, Full-Tracked: 105-MM Gun, M60A1 (NSN 2350-00-756-8497) and M60A1 (AOS) (2350-01-058-9487) (Reprinted W/Basic Incl C1-3) TM 9-2350-215-10-3
- Organizational Maintenance Manual for Tank, Combat, Full-Tracked: 105-MM Gun, M60A1 (NSN 2350-00-756-8497) (Hull) and M60A1 (AOS) (2350-01-058-9487) (Hull) (Reprinted W/Basic Incl C1) TM 9-2350-215-20-1-2
- Organizational Maintenance Manual for Tank, Combat, Full-Tracked: 105-MM Gun, M60A1 (NSN 2350-00-756-8497) (Hull) and M60A1 (AOS) (2350-01-058-9487) (Hull) TM 9-2350-215-20-1-3
- Organizational Maintenance Manual for Tank, Combat, Full-Tracked: 105-MM Gun, M60A1 (NSN 2350-00-756-8497) (Hull) and M60A1 (AOS) (2350-01-058-9487) (Hull) (Reprinted W/Basic Incl C1-3) TM 9-2350-215-20-1-4

REFERENCE WORK PACKAGE - CONTINUED

0014 00

Direct Support and General Support Maintenance Repair Parts and Special Tools Lists (Including Depot Maintenance Repair Parts and Special Tools) for Engine w/Container: Turbosupercharged, Oil-Cooled Generator, Diesel, Fuel Injection, 90 Degree, V-Type, Air-Cooled, 12-Cylinder Assembly; Model AVDS-1790-8CR (TM 07769B-34/6). (This item is included on EM 0160) TM 9-2815-247-34P

Direct Support and General Support Maintenance Manual for Engine w/Container: Turbosupercharged, Diesel, Fuel Injection, 90 Degree, V-Type, Air-Cooled, 12-Cylinder Assembly; Model AVDS-1790-8CR (NSN 2815-01-414-6821) (TM 07769B-34/5). (This item is included on EM 0160) TM 9-2815-247-34

SUPPLY CATALOGS

Sets, Kits, and Outfits for Shop Equipment, Automotive Maintenance and Repair: Field Maintenance, Basic, Less Power (NSN 4910-00-754-0705) (LIN T24660) (EIC: 2J2) ... SC 4910-95-A31

Sets, Kits, Outfits, and Tools for Shop Equipment, Automotive Maintenance and Repair: Field Maintenance, Supplemental Set No. 2, Less Power (NSN 4910-00-754-0707) (LIN T25756) (EIC: 2J4) and Shop Equipment, Automotive Maintenance and Repair: Field Maintenance, Supplemental Set No. 2 Map Only SC 4910-95-A63

SPECIFICATIONS AND STANDARDS

Standard Practice for Fabrication of Fiberboard Shipping Boxes. ASTM D 5118

PUBLICATION INDEXES

The following indexes should be consulted frequently for latest changes or revisions to references given in the appendix and for new publications relating to material covered in this Technical Manual.

Consolidated Index of Army Publications and Blank Forms (Issued Quarterly) (No Printed Copies Exist) (Formerly DA PAM 310-1) PAM 25-30
 The Army Maintenance Management System (TAMMS) Users Manual PAM 750-8

END OF WORK PACKAGE

**DIRECT SUPPORT AND
GENERAL SUPPORT MAINTENANCE
REPAIR PARTS AND SPECIAL TOOLS LIST**

INTRODUCTION

SCOPE

This Work Package lists repair parts and special tools required for direct and general support maintenance of the Model 5HDR Turbosupercharger. It authorizes the requisitioning and issue of repair parts as indicated by the source and maintenance codes.

<u>Part Numbers</u>	<u>Engine Applications</u>
11668377-1 and 187727	AVDS-1790-2A AVDS-1790-2CA AVDS-1790-2D AVDS-1790-2DA AVDS-1790-2DR
655595-3(RB)	AVDS-1790-8CR
655595-4(LB)	AVDS-1790-8CR

GENERAL

In addition to the introduction, this work package is divided into the following areas.

1. Repair Parts List - A list of repair parts authorized for use in the performance of maintenance. This work package also includes parts which must be removed for replacement of the authorized parts. Parts lists are composed of functional groups in ascending alphanumeric sequence, with the parts in each group listed in ascending figure and item number sequence.
2. Special Tools List - A list of special tools authorized for the performance of maintenance.
3. Cross-Reference Index - There are two cross-reference indexes in this work package: the National Stock Number (NSN) and the Part Number (P/N) index. The National Stock Number Index refers you to the figure and item number. The Part Number Index refers you to the figure and item number.

EXPLANATION OF COLUMNS IN THE REPAIR PARTS AND SPECIAL TOOLS LIST

ITEM NO. (Column (1)). Indicates the number used to identify items called out in the illustration.

SMR CODE (Column (2)). The SMR code containing supply/requisitioning information, maintenance level authorization criteria, and disposition instruction, as shown in the following breakout:

<u>Source Code</u>	<u>Maintenance Code</u>		<u>Recoverability Code</u>
<u>XXxxx</u>	<u>xxXXX</u>		<u>xxxxX</u>
1 st two positions:	3 rd position:	4 th position:	5 th position:
How to get an item.	Who can install, replace, or use the item.	Who can do complete repair* on the item.	Who determines disposition action on unserviceable items.

*Complete Repair: Maintenance capacity, capability, and authority to perform all corrective maintenance tasks of the "Repair" function in a use/user environment in order to restore serviceability to a failed item.

Source Code. The source code tells you how you get an item needed for maintenance, repair, or overhaul of an end item/equipment. Explanations of source codes follow:

<u>Source Code</u>	<u>Application/Explanation</u>
PA	Stock items; use the applicable NSN to requisition/request items with these source codes. They are authorized to the level indicated by the code entered in the 3 rd position of the SMR code.
PB	
PC	
PD	
PE	
PF	
PG	

NOTE

Items coded PC are subject to deterioration.

Source Code**Application/Explanation**

KD KF KB	Items with these codes are not to be requested/requisitioned individually. They are part of a kit which is authorized to the maintenance level indicated in the 3rd position of the SMR code. The complete kit must be requisitioned and applied.
MO-Made at unit/AVUM level MF-Made at DS/AVIM level MH-Made at GS level ML-Made at SRA MD-Made at depot	Items with these codes are not to be requisitioned/requested individually. They must be made from bulk material which is identified by the P/N in the DESCRIPTION AND USABLE ON CODE (UOC) column and listed in the bulk material group work package of the RPSTL. If the item is authorized to you by the 3rd position code of the SMR code, but the source code indicates it is made at higher level, order the item from the higher level of maintenance.
AO-Assembled by unit/AVUM level AF-Assembled by DS/AVIM level AH-Assembled by GS level AL-Assembled by SRA AD-Assembled by depot	Items with these codes are not to be requested/requisitioned individually. The parts that make up the assembled item must be requisitioned or fabricated and assembled at the level of maintenance indicated by the source code. If the 3rd position of the SMR code authorizes you to replace the item, but the source code indicates the item is assembled at a higher level, order the item from the higher level of maintenance.
XA	Do not requisition an "XA" coded item. Order the next higher assembly. (Refer to NOTE below.)
XB	If an item is not available from salvage, order it using the CAGEC and P/N.
XC	Installation drawings, diagrams, instruction sheets, field service drawings; identified by manufacturer's P/N.
XD	Item is not stocked. Order an XD-coded item through normal supply channels using the CAGEC and P/N given, if no NSN is available.

NOTE

Cannibalization or controlled exchange, when authorized, may be used as a source of supply for items with the above source codes except for those items source coded "XA" or those aircraft support items restricted by requirements of AR 750-1.

Maintenance Code. Maintenance codes tell you the level(s) of maintenance authorized to use the repair support items. The maintenance codes are entered in the third and fourth positions of the SMR code as follows:

Third Position. The maintenance code entered in the third position tells you the lowest maintenance level authorized to remove, replace, and use an item. The maintenance code entered in the third position will indicate authorization to the following levels of maintenance:

Maintenance

<u>Code</u>	<u>Application/Explanation</u>
C	- Crew or operator maintenance done within unit/AVUM maintenance.
O	- Unit level/AVUM maintenance can remove, replace, and use the item.
F	- Direct support/AVIM maintenance can remove, replace, and use the item.
H	- General support maintenance can remove, replace, and use the item.
L	- Specialized repair activity can remove, replace, and use the item.
D	- Depot can remove, replace, and use the item.

Fourth Position. The maintenance code entered in the fourth position tells you whether or not the item is to be repaired and identifies the lowest maintenance level with the capability to do complete repair (perform all authorized repair functions).

NOTE

Some limited repair may be done on the item at the lower level of maintenance, if authorized by the SMR codes.

Maintenance

<u>Code</u>	<u>Application/Explanation</u>
O	- Unit/AVUM is the lowest level that can do complete repair of the item.
F	- Direct support/AVIM is the lowest level that can do complete repair of the item.
H	- General support is the lowest level that can do complete repair of the item.
L	- Specialized repair activity is the lowest level that can do complete repair of the item.
D	- Depot is the lowest level that can do complete repair of the item.
Z	- Nonreparable. No repair is authorized.
B	- No repair is authorized. No parts or special tools are authorized for maintenance of "B" coded item. However, the item may be reconditioned by adjusting, lubricating, etc., at the user level.

Recoverability Code. Recoverability codes are assigned to items to indicate the disposition action on unserviceable items. The recoverability code is shown in the fifth position of the SMR code as follows:

Recoverability

<u>Code</u>	<u>Application/Explanation</u>
Z	- Nonreparable item. When unserviceable, condemn and dispose of the item at the level of maintenance shown in the third position of the SMR code.
O	- Reparable item. When uneconomically repairable, condemn and dispose of the item at the unit level.
F	- Reparable item. When uneconomically repairable, condemn and dispose of the item at the direct support level.
H	- Reparable item. When uneconomically repairable, condemn and dispose of the item at the general support level.
D	- Reparable item. When beyond lower level repair capability, return to depot. Condemnation and disposal of item is not authorized below depot level.
L	- Reparable item. Condemnation and disposal not authorized below Specialized Repair Activity (SRA).
A	- Item requires special handling or condemnation procedures because of specific reasons (such as precious metal content, high dollar value, critical material, or hazardous material). Refer to appropriate manuals/directives for specific instructions.

NSN (Column (3)). The NSN for the item is listed in this column.

CAGEC (Column (4)). The Commercial and Government Entity Code (CAGEC) is a five-digit code which is used to identify the manufacturer, distributor, or Government agency/activity that supplies the item.

PART NUMBER (Column (5)). Indicates the primary number used by the manufacturer (individual, company, firm, corporation, or Government activity), which controls the design and characteristics of the item by means of its engineering drawings, specifications, standards, and inspection requirements to identify an item or range of items.

NOTE

When you use an NSN to requisition an item, the item you receive may have a different P/N from the number listed.

DESCRIPTION AND USABLE ON CODE (UOC) (Column (6)). This column includes the following information:

1. The federal item name, and when required, a minimum description to identify the item.
2. P/Ns of bulk materials are referenced in this column in the line entry to be manufactured or fabricated.
3. Hardness Critical Item (HCI). A support item that provides the equipment with special protection from Electromagnetic Pulse (EMP) damage during a nuclear attack.
4. The statement END OF FIGURE appears just below the last item description in column (6) for a given figure in both the repair parts list and special tools list.

QTY (Column (7)). The QTY (quantity per figure) column indicates the quantity of the item used in the breakout shown on the illustration/figure, which is prepared for a functional group, subfunctional group, or an assembly. A "V" appearing in this column instead of a quantity indicates that the quantity is variable and quantity may change from application to application.

EXPLANATION OF CROSS-REFERENCE INDEX FORMAT AND COLUMNS

1. National Stock Number (NSN) Index.

STOCK NUMBER Column. This column lists the NSN in National Item Identification Number (NIIN) sequence. The NIIN consists of the last nine digits of the NSN.

NSN
(e.g., 5385-01-574-1476)
NIIN

When using this column to locate an item, ignore the first four digits of the NSN. However, the complete NSN should be used when ordering items by stock number.

FIG. Column. This column lists the number of the figure where the item is identified/located. The figures are in numerical order in the repair parts list and special tools list.

ITEM Column. The item number identifies the item associated with the figure listed in the adjacent FIG. column. This item is also identified by the NSN listed on the same line.

2. Part Number (P/N) Index. P/Ns in this index are listed in ascending numeric-alpha sequence (vertical arrangement of number and letter combinations which places the first digit or letter of each group in order 0 through 9, followed by the letters A through Z and each following digit or letter in like order).

PART NUMBER Column. Indicates the P/N assigned to the item.

FIG. Column. This column lists the number of the figure where the item is identified/located in the repair parts list and special tools list.

ITEM Column. The item number is in the number assigned to the item as it appears in the figure referenced in the adjacent figure number column.

SPECIAL INFORMATION

UOC. The UOC appears in the lower left corner of the Description Column heading. Usable on codes are shown as "UOC:..." in the Description Column (justified left) on the first line under the applicable item/nomenclature. Uncoded items are applicable to all models. Identification of the usable on codes in this publication are:

Code	Used ON
A	8717421
B	10889713
C	11642898

Item Numbers. Items which have the word BULK in the figure column will have an index number shown in the item number column. This index number is a cross-reference between the NSN / P/N index and the bulk material list in the repair parts list.

Repair Parts Kits. Repair parts kits appear as the last entries in the repair parts listing for the figure in which its parts are listed as repair parts.

Special Tool Sets. Special tool sets are stocked for initial issue. Tool set components are requisitioned as individual items. Stockage of tools that are duplicated in tool sets for other vehicles assigned or supported are not required beyond actual need.

HOW TO LOCATE REPAIR PARTS

1. When NSNs or P/Ns are not known.

- A. Using the table of contents, determine the assembly group to which the item belongs. This is necessary since figures are prepared for assembly groups and subassembly groups, and lists are divided into the same groups.
- B. Find the figure covering the functional group or the subfunctional group to which the item belongs.
- C. Identify the item on the figure and note the number(s).
- D. Look in the repair parts list work packages for the figure and item numbers. The NSNs and part numbers are on the same line as the associated item numbers.

2. When NSN is known.

- A. If you have the NSN, look in the Stock Number column of the NSN index. The NSN is arranged in NIIN sequence. Note the figure and item number next to the NSN.
- B. Turn to the figure and locate the item number. Verify that the item is the one you are looking for.

3. When P/N is known.

- A. If you have the P/N and not the NSN, look in the Part Number column of the P/N index. Identify the figure and item number.
- B. Look up the item on the figure in the applicable repair parts list.

ABBREVIATIONS

<u>Abbreviation</u>	<u>Explanation</u>
FIG	Figure
NSN	National Stock Number
RPSTL	Repair Parts and Special Tools List
SMR	Source, Maintenance, and Recoverability
TMDE	Test, Measurement, and Diagnostic Equipment
UOC	Usable on Code

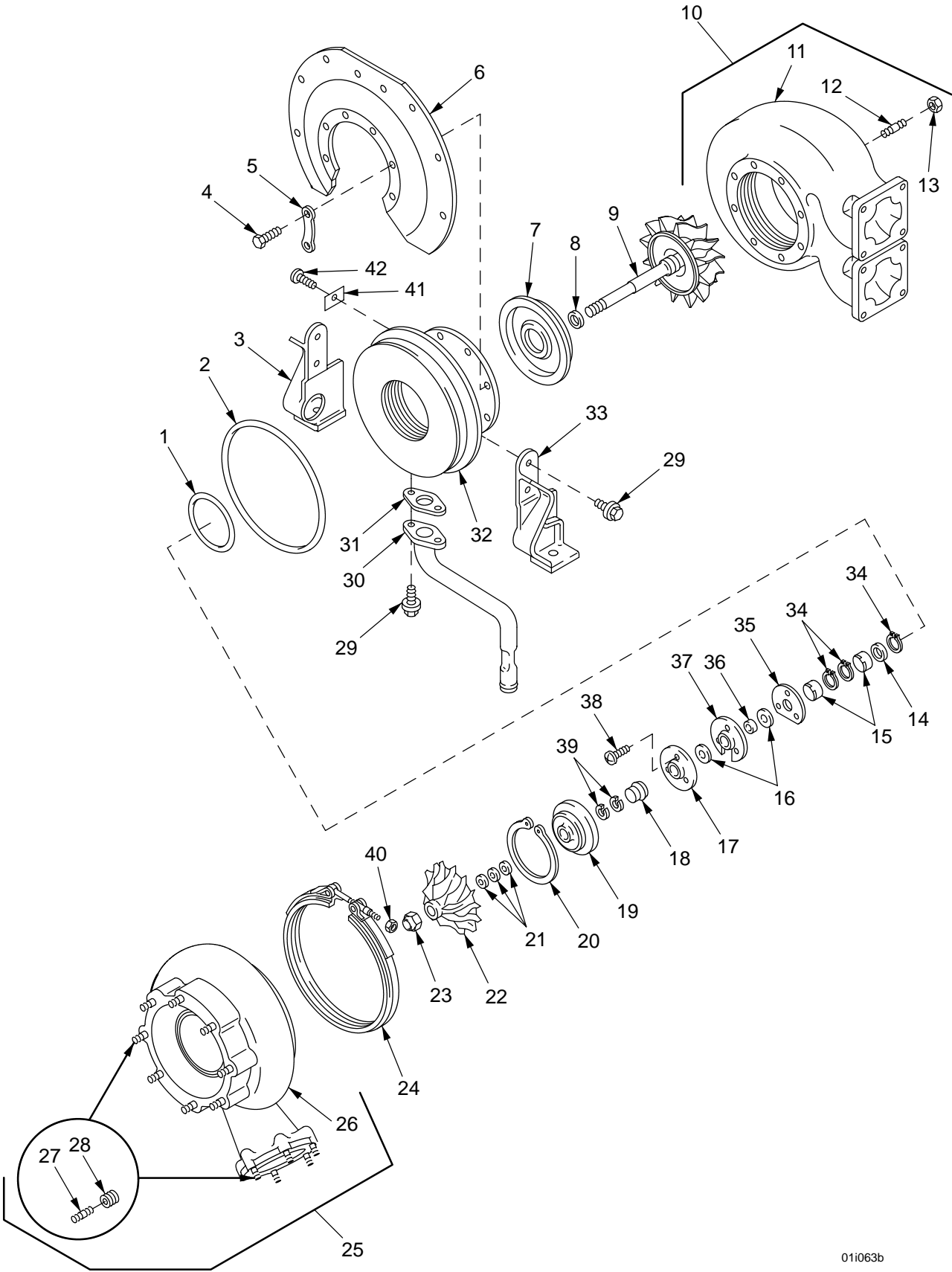

01i063b

Figure 1. Turbosupercharger Assembly.

(1) ITEM NO	(2) SMR	(3) NSN	(4) CAGE	(5) PART NUMBER	(6) DESCRIPTION AND USABLE ON CODE (UOC)	(7) QTY
					GROUP 0305 TURBOSUPERCHARGER MODEL 5HDR, PART NO. 11668377-1 FIGURE 1 TURBOSUPERCHARGER	
1	KFHZZ		53591	183234	PACKING, PREFORMED PART OF KIT P/N 5705073	1
2	PAHZZ	5330-00-486-0417	53591	138201	PACKING, PREFORMED PART OF KIT P/N 5705073	1
3	PBHZZ	2990-01-292-8579	53591	157571	MOUNTING LEG, TURBOS	1
4	XAHZZ	5305-00-576-5417	53591	140319	SCREW, CAP, HEXAGON H	8
5	KFHZZ		53591	157617	LOCKING PLATE PART OF KIT P/N 5705073	4
6	PAHZZ	2950-01-053-7200	53591	157615	SHIELD, TURBOCHARGER	1
7	XAHZZ		53591	158568	BACKPLATE, TURBINE	1
8	KFHZZ		53591	142114	SEAL, RING, METAL PART OF KIT P/N 5705073	1
9	PFHZZ	2950-00-397-3363	53591	152258	TURBINE WHEEL ASSEM	1
10	XAHHH		53591	158581	HOUSING, TURBINE ASS	1
11	XAHZZ		53591	157809	HOUSING, TURBINE	1
12	PAHZZ	5307-00-492-3217	53591	C157415	STUD, PLAIN	6
13	PAOZZ	5310-01-151-2732	19207	12275894	NUT, SELF-LOCKING HE	6
14	PAHZZ	3120-00-413-9604	53591	140029	BEARING, WASHER, THRU PART OF KIT P/N 5705073	1
15	KFHZZ		53591	135619	BEARING, SLEEVE PART OF KIT P/N 5705073	2
16	PAHZZ	2950-00-118-8535	53591	2S1185	BEARING, WASHER, THRU PART OF KIT P/N 5705073	1
17	XAHZZ		53591	137856	DEFLECTOR, OIL	1
18	PAHZZ	2990-00-970-7553	53591	135796	SLEEVE, FLINGER PART OF KIT P/N 5705073	1
19	KFHZZ		53591	189814	INSERT, FLINGER SLEEVE PART OF KIT P/N 5705073	1
20	PAHZZ	5365-00-115-1475	53591	139052	RING, RETAINING	1
21	PAHZZ	5365-00-103-9189	89619	375SB16P1	SHIM (0.003 THICK) PART OF KIT P/N 5705073	1
21	PAHZZ	5365-00-104-2124	89616	375SB16P2	SHIM (0.005 THICK) PART OF KIT P/N 5705073	1
21	PAHZZ	5365-00-103-9191	64104	701569B	SHIM (0.010 THICK) PART OF KIT P/N 5705073	1
22	PAHZZ	4310-00-423-3892	53591	191634	IMPELLER, FAN, AXIAL	1
23	KFHZZ		53591	146164	NUT, LOCK PART OF KIT P/N 5705073	1
24	PFHZZ	2990-00-235-1709	53591	140153	CLAMP	1
25	XAHHH		53591	157229	COVER, COMPRESSOR ASSE	1
26	XAHZZ		53591	157148	COVER, COMPRESSOR	1
27	PFHZZ	5307-01-008-6182	53591	C157631	STUD, PLAIN	14
28	PAHZZ	5340-00-290-4520	96906	MS21208C5-20	INSERT, SCREW THREAD	V
29	PAHZZ	5305-00-500-0435	53591	132575	SCREW, CAP, HEXAGON, H	6
30	PAFZZ	4710-00-432-0055	53591	157599	TUBE ASSEMBLY, METAL	1
31	PAFZZ	5330-01-059-0096	53591	184054	GASKET	1
32	XAHZZ		53591	157542	HOUSING, BEARING	1

(1) ITEM NO	(2) SMR	(3) NSN	(4) CAGE	(5) PART NUMBER	(6) DESCRIPTION AND USABLE ON CODE (UOC)	(7) QTY
33	XAHZZ		53591	157572	LEG, MOUNTING	1
34	PAHZZ	5365-00-655-8113	96906	MS16627-1106	RING, RETAINING	3
35	KFHZZ		53591	137945	SPACER PART OF KIT P/N 5705073	1
36	PAHZZ	3120-00-087-2704	53591	137016	BEARING, SLEEVE PART OF KIT P/N 5705073	1
37	KFHZZ		53591	146827	BEARING, THRUST PART OF KIT P/N 5705073	1
38	KFHZZ		53591	158567	SCREW OIL DEFLECTOR PART OF KIT P/N 5705073	3
39	PAHZZ	2990-00-858-6206	19207	7383439	SEAL RING, METAL PART OF KIT P/N 5705073	2
40	PAHZZ	5310-00-298-2747	96906	MS20500-428	NUT, SELF-LOCKING, HE	1
41	XAHZZ		53591	157482	PLATE, IDENTIFICATION	1
42	XAHZZ		53591	129309	SCREW, DRIVE	1
	PAHZZ	2990-01-152-2373	19207	5705073	PARTS KIT, TURBOCHAR	
					PACKING, PREFORMED (1) B1-1	
					PACKING, PREFORMED (1) B1-2	
					LOCKING, PLATE (4) B1-5	
					SEAL, RING, METAL (1) B1-8	
					BEARING, WASHER, THRU (1) B1-14	
					BEARING, SLEEVE (2) B1-15	
					BEARING, WASHER, THRU (2) B1-16	
					SLEEVE, FLINGER (1) B1-18	
					INSERT, FLINGER SLEE (1) B1-19	
					SHIM (3) B1-21	
					SHIM (3) B1-21	
					SHIM (3) B1-21	
					NUT, LOCK (1) B1-23	
					SPACER (1) B1-35	
					BEARING, SLEEVE (1) B1-36	
					BEARING, THRUST (1) B1-37	
					SCREW, OIL DEFLECTOR (3) B1-38	
					SEAL, RING, METAL (2) B1-39	

END OF FIGURE

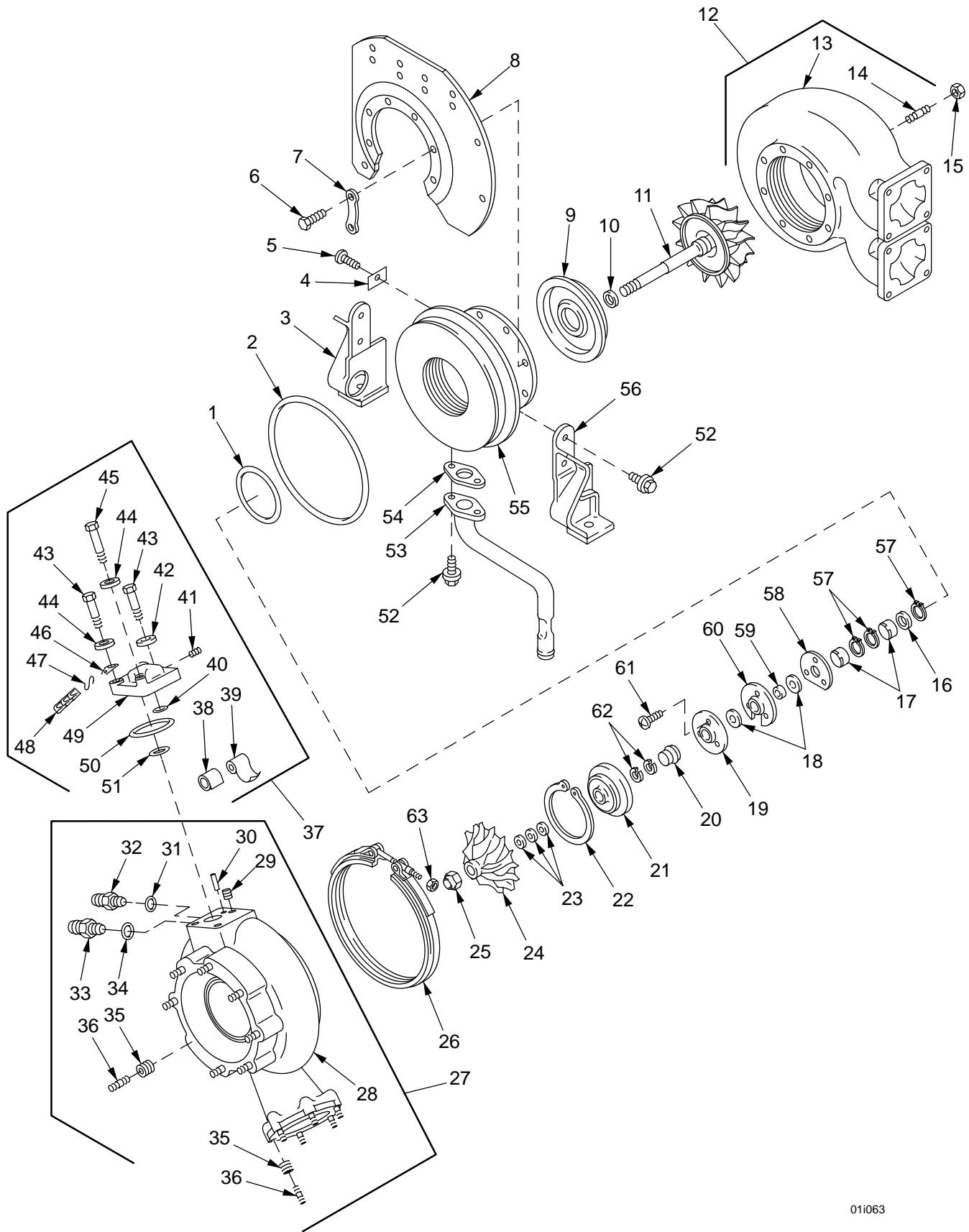

01i063

Figure 2. Turbosupercharger Assembly 187727.

(1) ITEM NO	(2) SMR	(3) NSN	(4) CAGE	(5) PART NUMBER	(6) DESCRIPTION AND USABLE ON CODE (UOC)	(7) QTY
					GROUP 0305 TURBOSUPERCHARGER MODEL 5HDR, PART NO. 187727 FIGURE 2 TURBOSUPERCHARGER	
1	PAHZZ	5330-00-806-4171	96906	MS29561-238	PACKING, PREFORMED PART OF KIT P/N 5705073	1
2	PAHZZ	5330-00-486-0417	53591	138201	PACKING, PREFORMED PART OF KIT P/N 5705073	1
3	PBHZZ	2990-01-292-8579	53591	157571	MOUNTING LEG, TURBOS	1
4	XAHZZ		53591	193898	PLATE, IDENTIFICATION	1
5	XAHZZ		53591	186752	RIVET	1
6	PAHZZ	5305-00-576-5417	96906	MS35307-360	SCREW, CAP, HEXAGON H	8
7	KFHZZ		53591	157617	LOCKING PLATE, NUT A PART OF KIT P/N 5705073	4
8	PAHZZ	2950-01-053-7200	53591	157615	SHIELD	1
9	XAHZZ		53591	158568	BACKPLATE, TURBINE.....	1
10	PAHZZ		53591	142114	PISTON RING PART OF KIT P/N 5705073	1
11	PFHZZ	2950-00-397-3363	53591	152258	TURBINE WHEEL ASSEM	1
12	XAHHH		53591	158581	HOUSING ASSEMBLY, TU	1
13	XAHZZ		53591	157809	HOUSING, TURBINE	1
14	PAHZZ	5307-00-492-3217	53591	C157415	STUD, PLAIN	6
15	PAOZZ	5310-01-151-2732	15653	SPL51712-6	NUT, SELF-LOCKING, H	6
16	PAHZZ	3120-00-413-9604	53591	140029	BEARING, WASHER, THRU PART OF KIT P/N 5705073	1
17	KFHZZ		53591	135619	BEARING, SLEEVE PART OF KIT P/N 5705073	2
18	PAHZZ	3120-00-118-8535	11083	2S1185	BEARING, WASHER, THRU PART OF KIT P/N 5705073	1
19	XAHZZ		53591	137856	DEFLECTOR, OIL	1
20	PAHZZ	2990-00-970-7553	53591	135796	SLEEVE, FLINGER PART OF KIT P/N 5705073	1
21	KFHZZ		53591	189814	INSERT, FLINGER SLEE PART OF KIT P/N 5705073	1
22	PAHZZ	5365-00-226-9996	96906	MS16631-1350	RING, RETAINING	1
23	PAHZZ	5365-00-103-9191	64104	701569B	SHIM 0.010 THICK PART OF KIT P/N 5705073	1
23	PAHZZ	5365-00-103-9189	89619	375SB16P1	SHIM 0.003 THICK PART OF KIT P/N 5075073	1
23	PAHZZ	5365-00-104-2124	89619	375SB16P2	SHIM 0.005 THICK PART OF KIT P/N 5705073	1
24	PAHZZ	4310-00-432-3892	53591	157149	WHEEL, COMPRESSOR	1
25	PAHZZ		53591	146164	NUT, LOCK PART OF KIT P/N 5705073	1
26	PAHZZ	2990-00-235-1709	53591	140153	CLAMP	1
27	XAHHH		53591	184910	COVER, COMPRESSOR	1
28	XAHZZ		53591	184907	COVER, COMPRESSOR	1
29	PAHZZ	5340-00-582-7256	96906	MS21209F5-20	INSERT, SCREW THREAD	3
30	PAHZZ	5340-00-815-3250	96906	MS39086-101	PIN, SPRING	2
31	PAOZZ	5330-00-833-7491	96906	MS28778-5	PACKING, PREFORMED PART OF KIT P/N 5705073	1

(1) ITEM NO	(2) SMR	(3) NSN	(4) CAGE	(5) PART NUMBER	(6) DESCRIPTION AND USABLE ON CODE (UOC)	(7) QTY
32	PAOZZ	4730-01-007-5232	96906	MS51525A4	ADAPTER, STRAIGHT, TU	1
33	PAOZZ	4730-00-431-9307	96906	MS51525A5	ADAPTER, STRAIGHT, TU	1
34	PAOZZ	5330-00-805-2966	96906	MS28778-4	PACKING, PREFORMED PART OF KIT P/N 5705073	1
35	PAHZZ	5340-00-290-4520	96906	MS122162	INSERT, SCREW THREAD	1
36	PAHZZ	5307-01-008-6182	53591	C157631	STUD, PLAIN	14
37	AFFFF		19207	12275864	COVER ASSEMBLY	1
38	PAFZZ	5340-01-145-8291	19207	12275868	STRAP, RETAINING	1
39	PAFZZ	4460-01-145-8299	19207	12275840	FILTER, AIR, ELECTROS	1
40	PAFZZ	5330-00-724-7902	96906	MS9068-013	PACKING, PREFORMED PART OF KIT P/N 5705073	1
41	PAFZZ	4730-00-277-6352	96906	MS27769-1	PLUG, PIPE	1
42	PAFZZ	5330-00-297-6468	83259	600-001-5-16	PACKING WITH RETAIN PART OF KIT P/N 5705073	1
43	PAFZZ	5305-01-145-8286	19207	12275866-1	SCREW, EXTERNALLY RE	2
44	PAFZZ	5310-00-194-0636	96906	MS9320-11	WASHER, FLAT	2
45	PAFZZ	5305-01-145-8287	19207	12275866-2	SCREW, EXTERNALLY RE	1
46	PAFZZ	4030-01-145-8293	19207	12275867	CHAIN FASTENER, ANGL	2
47	PAFZZ	4030-00-270-5436	96906	MS87006-3	HOOK, CHAIN, S	2
48	PAFZZ	4010-01-157-1343	19207	12275841	CHAIN, WELDLESS	1
49	PBFZZ	5340-01-145-8310	19207	12275869	COVER, ACCESS	1
50	PAFZZ	5330-00-180-9951	96906	MS9068-038	PACKING, PREFORMED PART OF KIT P/N 5705073	1
51	PAFZZ	5330-00-724-5541	96906	MS90687-018	PACKING, PREFORMED PART OF KIT P/N 5705073	1
52	PAHZZ	5305-00-500-0435	53591	132575	SCREW, CAP, HEXAGON H	6
53	PAHZZ	4710-00-432-0055	53591	157599	TUBE ASSEMBLY, METAL	1
54	PAHZZ	5330-01-059-0096	53591	184054	GASKET	1
55	XAHZZ		51591	157542	HOUSING, BEARING	1
56	PBHZZ	5340-01-300-0409	53591	157572	BRACKET, MOUNTING	1
57	PAHZZ	5365-00-655-8113	96906	MS16627-1106	RING, RETAINING	1
58	KFHZZ		53591	137945	SPACER PART OF KIT P/N 5705073	3
59	PAHZZ	3120-00-087-2704	53591	137016	BEARING, SLEEVE PART OF KIT P/N 5705073	1
60	KFHZZ		53591	146827	BEARING, THRUST PART OF KIT P/N 5705073	1
61	KFHZZ		53591	158567	SCREW, OIL DEFLECTOR PART OF KIT P/N 5705073	3
62	PAHZZ	2990-00-858-6206	19207	7383439	SEAL RING, METAL PART OF KIT P/N 5705073	2
63	PAHZZ	5310-00-298-2747	96906	MS20500-428	NUT, SELF-LOCKING, HE	1
	PAHZZ	2990-01-152-2373	19207	5705073	PARTS KIT, TURBOCHAR PACKING, PREFORMED (1) B2-1 PACKING, PREFORMED (1) B2-2 LOCKING PLATE (4) B2-7 PISTON RING (1) B2-10 BEARING, WASHER, THRU (1) B2-16 BEARING, SLEEVE (2) B2-17 BEARING, WASHER, THRU (1) B2-18 SLEEVE, FLINGER (1) B2-20	

(1) ITEM NO	(2) SMR	(3) NSN	(4) CAGE	(5) PART NUMBER	(6) DESCRIPTION AND USABLE ON CODE (UOC)	(7) QTY
					INSERT, FLINGER SLEE	(1) B2-21
					SHI M	(3) B2-23
					SHI M	(3) B2-23
					SHI M	(3) B2-23
					NUT, LOCK	(1) B2-25
					PACKING, PREFORMED	(1) B2-31
					PACKING, PREFORMED	(1) B2-34
					PACKING, PREFORMED	(1) B2-40
					PACKING, WITH RETAIN	(1) B2-42
					PACKING, PREFORMED	(1) B2-50
					PACKING, PREFORMED	(1) B2-51
					SPACER	(1) B2-58
					BEARING, SLEEVE	(1) B2-59
					BEARING, THRUST	(1) B2-60
					SCREW, OIL DEFLECTOR	(3) B2-61
					SEAL, RING, METAL	(2) B2-62

END OF FIGURE

(1) ITEM NO	(2) SMR	(3) NSN	(4) CAGE	(5) PART NUMBER	(6) DESCRIPTION AND USABLE ON CODE (UOC)	(7) QTY
					GROUP 0305 TURBOSUPERCHARGER PART NO. 655595-3 RIGHT BANK PART NO. 655595-4 LEFT BANK FIGURE 3 TURBOSUPERCHARGER	
1	PAHZZ	5330-00-806-4171	96906	MS29561-238	PACKING, PREFORMED PART OF KIT P/N E8CR131-0160	1
2	PAHZZ	5330-00-486-0417	53591	138201	PACKING, PREFORMED PART OF KIT P/N E8CR131-0160	1
3	PBHZZ	2990-01-292-8579	53591	157571	MOUNTING LEG, TURBOS	1
4	XAHZZ		53591	193898	PLATE, IDENTIFICATION	1
5	XAHZZ		53591	186752	RIVET	1
6	PAHZZ	5305-00-576-5417	96906	MS35307-360	SCREW, CAP, HEXAGON H	8
7	KFHZZ		53591	157617	LOCKING PLATE, NUT A PART OF KIT P/N E8CR131-0160	4
8	PAHZZ	2990-01-437-8266	53591	193801	HEAT SHIELD USED ON LEFT BANK	1
8	PAHZZ	2990-01-437-1570	53591	182349	HEAT SHIELD USED ON RIGHT BANK	1
9	XAHZZ		53591	158568	BACKPLATE, TURBINE	1
10	PAHZZ	2815-01-434-5208	53591	142114	PISTON RING PART OF KIT P/M E8CR131-0160	1
11	PFHZZ		53591	191804	WHEEL ASSEMBLY	1
12	XAHHH		53591	194671	HOUSING ASSEMBLY, TU	1
13	XAHZZ		53591	192766	HOUSING, TURBINE	1
14	PAHZZ	5307-00-492-3217	53591	C157415	STUD, PLAIN	6
15	PAOZZ	5310-01-151-2732	15653	SPL51712-6	NUT, SELF-LOCKING, H	6
16	PAHZZ	3120-00-413-9604	53591	140029	BEARING, WASHER, THRU PART OF KIT P/N E8CR131-0160	1
17	KFHZZ		53591	135619	BEARING, SLEEVE PART OF KIT P/N E8CR131-0160	2
18	PAHZZ	3120-00-118-8535	11083	2S1185	BEARING, WASHER, THRU PART OF KIT P/N E8CR131-0160	2
19	XAHZZ		53591	137856	DEFLECTOR, OIL	1
20	PAHZZ	2990-00-970-7553	53591	135796	SLEEVE, FLINGER PART OF KIT P/N E8CR131-0160	1
21	KFHZZ		53591	189814	INSERT, FLINGER SLEEVE PART OF KIT P/N E8CR131-0160	1
22	PAHZZ	5365-00-226-9996	96906	MS16631-1350	RING, RETAINING	1
23	PAHZZ	5365-00-103-9191	64104	701569B	SHIM 0.010 THICK PART OF KIT P/N E8CR131-0160	3
23	PAHZZ	5365-00-103-9189	89619	375SB16P1	SHIM 0.003 THICK PART OF KIT P/N E8CR131-0160	3
23	PAHZZ	5365-00-104-2124	89619	375SB16P2	SHIM 0.005 THICK PART OF KIT P/N E8CR131-0160	3
24	PAHZZ	2930-01-434-5503	53591	191634	WHEEL, COMPRESSOR	1
25	PAHZZ	5310-01-433-8977	53591	194118	NUT, LOCK	1
26	PAHZZ	2990-00-235-1709	53591	140153	CLAMP	1
27	XAHHH		53591	191695	COVER, COMPRESSOR	1
28	XAHZZ		53591	191635	COVER, COMPRESSOR	1
29	PAOZZ	5330-00-833-7491	96906	MS28778-5	PACKING, PREFORMED PART OF KIT P/N E8CR131-0160	1
30	PAOZZ	5340-00-815-3250	96906	MS51525A4	ADAPTER, STRAIGHT	1

31	PAHZZ	5340-00-582-7256	96906	MS21209F5-20	INSERT, SCREW THREAD	V
32	PAHZZ	5315-00-815-3250	96906	MS39086-101	PIN, SPRING	2
33	PAOZZ	5330-00-805-2966	96906	MS28778-4	PACKING, PREFORMED PART OF KIT P/N E8CR131-0160	1
34	PAOZZ	4730-00-431-9307	81343	5-5 070120CA	ADAPTER, STRAIGHT, TU	1
35	PAHZZ	5340-00-290-4520	96906	MS122162	INSERT, SCREW THREAD	V
36	PAHZZ	5307-01-008-6182	53591	C157631	STUD, PLAIN	14
37	A0000		19207	12275864	COVER ASSEMBLY	1
38	PAOZZ	5340-01-145-8291	19207	12275868	STRAP, RETAINING	1
39	PAOZZ	4460-01-145-8299	19207	12275840	FILTER, AIR, ELECTROS	1
40	PAOZZ	5330-00-724-7902	96906	MS9068-013	PACKING, PREFORMED PART OF KIT P/N E8CR131-0160	1
41	PAOZZ	4730-00-277-6352	96906	MS27769-1	PLUG, PIPE	1
42	PAOZZ	5330-00-297-6468	83259	600-001-5-16	PACKING WITH RETAIN PART OF KIT P/N E8CR131-0160	1
43	PAOZZ	5305-01-145-8286	19207	12275866-1	SCREW, EXTERNALLY RE	2
44	PAOZZ	5310-00-194-0636	96906	MS9320-11	WASHER, FLAT	2
45	PAOZZ	5305-01-145-8287	19207	12275866-2	SCREW, EXTERNALLY RE	1
46	PAOZZ	4030-01-145-8293	19207	12275867	CHAIN FASTENER, ANGL	2
47	PAOZZ	4030-00-270-5436	96906	MS87006-3	HOOK, CHAIN, S	2
48	PAOZZ	4010-01-157-1343	19207	12275841	CHAIN, WELDLESS	1
49	PBOZZ	5340-01-145-8310	19207	12275869	COVER, ACCESS	1
50	PAOZZ	5330-00-180-9951	96906	MS9068-038	PACKING, PREFORMED PART OF KIT P/N E8CR131-0160	1
51	PAOZZ	5330-00-724-5541	96906	MS90687-018	PACKING, PREFORMED PART OF KIT P/N E8CR131-0160	1
52	PAHZZ	5305-00-500-0435	53591	132575	SCREW, CAP, HEXAGON H	6
53	PAHZZ	4710-00-432-0055	53591	157599	TUBE ASSEMBLY, METAL	1
54	PAHZZ	5330-01-059-0096	53591	184054	GASKET	1
55	XAHZZ		51591	157542	HOUSING, BEARING	1
56	PBHZZ	5340-01-300-0409	53591	157572	BRACKET, MOUNTING	1
57	PAHZZ	5365-00-655-8113	96906	MS16627-1106	RING, RETAINING	1
58	KFHZZ		53591	137945	SPACER PART OF KIT P/N E8CR131-0160	1
59	PAHZZ	3120-00-087-2704	53591	137016	BEARING, SLEEVE PART OF KIT P/N E8CR131-0160	1
60	PAHZZ		53591	146827	BEARING, THRUST	1
61	KFHZZ		53591	158567	SCREW, MACHINE PART OF KIT P/N E8CR131-0160	3
62	PAHZZ	2990-00-858-6206	53591	125647	SEAL RING, METAL PART OF KIT P/N E8CR131-0160	2
63	PAHZZ	5310-00-298-2747	96906	MS20500-428	NUT, SELF-LOCKING, HE	1
	PAHZZ	2990-01-152-2373	19207	E8CR131-0160	PARTS KIT, TURBOCHAR PACKING, PREFORMED (1) B3-1 PACKING, PREFORMED (1) B3-2 LOCKING PLATE (4) B3-7 PISTON RING (1) B3-10 NUT, SELF-LOCKING (6) B3-15 BEARING, WASHER, THRU (1) B3-16 BEARING, SLEEVE (2) B3-17 BEARING, WASHER, THRU (2) B3-18 SLEEVE, FLINGER (1) B3-20 INSERT, FLINGER SLEE (1) B3-21	

SHI M	(1)	B3-23
SHI M	(1)	B3-23
SHI M	(1)	B3-23
PACKI NG, PREFORMED	(1)	B3-29
PACKI NG, PREFORMED	(1)	B3-33
PACKI NG, PREFORMED	(1)	B3-40
PACKI NG, WITH RETAIN	(1)	B3-42
PACKI NG, PREFORMED	(1)	B3-50
PACKI NG, PREFORMED	(1)	B3-51
SPACER	(1)	B3-58
BEARI NG, SLEEVE	(1)	B3-59
BEARI NG, THRUST	(1)	B3-60
SCREW, MACHI NE	(3)	B3-61
PISTON RI NG	(2)	B3-62

END OF FIGURE

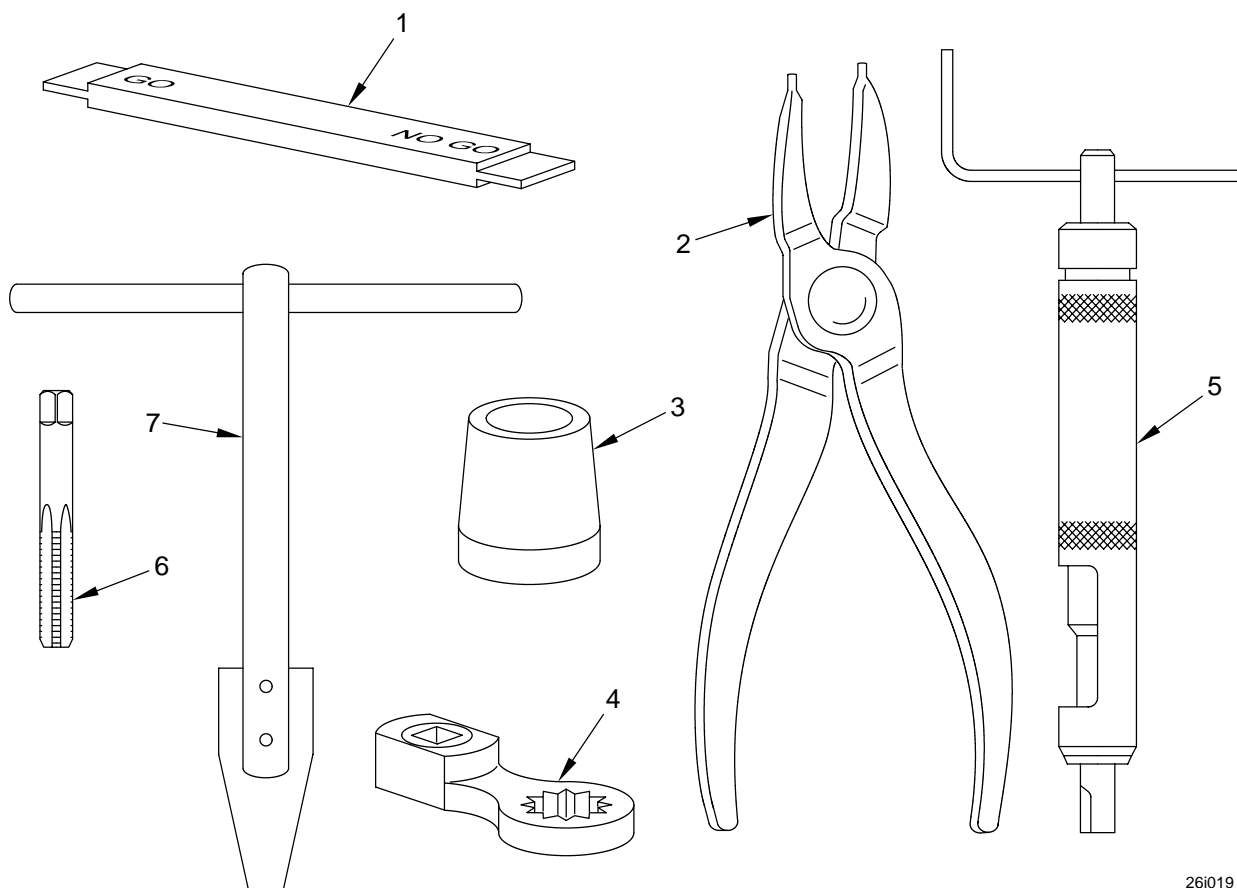

261019

Figure 4. Special Tools.

(1) ILLUSTRATION		(2)	(3)	(4)	(5)	(6)	(7)	(8)
(a) FIG NO.	(b) ITEM NO.	SMR CODE	NATIONAL STOCK NUMBER	PART NUMBER	FSCM	DESCRIPTION	U/M	QTY INC IN UNIT
						GROUP - 2604		
4	1	PEHZZ	4910-00-793-5030	10882675	19207	GAGE, TURBOCHARGER	EA	1
4	2	PEHZZ	5120-00-792-8624	10935598	19207	PLIERS, RETAINING RING	EA	1
4	3	PEHZZ	4910-00-870-2122	10899149	19207	SLEEVE, INSTALLING: FLINGER SLEEVE AND SHAFT SEAL RING EXPANDER	EA	1
4	4	PEHZZ	5120-00-323-4875	8708189	19207	WRENCH, BOX: BEARING HOUSING	EA	1
4	5	PEHZZ	5120-00-804-6055	7551-5	01556	INSERTER, SCREW THREAD: 5/16-18	EA	1
4	6	PEHZZ	5136-00-276-1031	B94.9	05047	TAP, THREAD: 5/16-18 (SPECIAL)	EA	1
4	7	PEHZZ	5120-00-723-6833	1227.6	01556	EXTRACTOR, SCREW THREAD INSERT: NO. 10-3/8	EA	1

NATIONAL STOCK AND PART NUMBER INDEXES
 NATIONAL STOCK NUMBER CROSS REFERENCE TO FIGURE AND ITEM NUMBER

NATIONAL STOCK NUMBER	FIGURE NO	ITEM NO	NATIONAL STOCK NUMBER	FIGURE NO	ITEM NO
3120-00-087-2704	1	36	5340-00-582-7256	3	31
3120-00-087-2704	2	59	5365-00-655-8113	1	34
3120-00-087-2704	3	59	5365-00-655-8113	2	57
5365-00-103-9189	1	21	5365-00-655-8113	3	57
5365-00-103-9189	2	23	5330-00-724-5541	2	51
5365-00-103-9189	3	23	5330-00-724-5541	3	51
5365-00-103-9191	1	21	5330-00-724-7902	2	40
5365-00-103-9191	2	23	5330-00-724-7902	3	40
5365-00-103-9191	3	23	5330-00-805-2966	2	34
5365-00-104-2124	1	21	5330-00-805-2966	3	33
5365-00-104-2124	2	23	5330-00-806-4171	2	1
5365-00-104-2124	3	23	5330-00-806-4171	3	1
5365-00-115-1475	1	20	5315-00-815-3250	3	32
2950-00-118-8535	1	16	5340-00-815-3250	2	30
3120-00-118-8535	2	18	5340-00-815-3250	3	30
3120-00-118-8535	3	18	5330-00-833-7491	2	31
5330-00-180-9951	2	50	5330-00-833-7491	3	29
5330-00-180-9951	3	50	2990-00-858-6206	1	39
5310-00-194-0636	2	44	2990-00-858-6206	2	62
5310-00-194-0636	3	44	2990-00-858-6206	3	62
5365-00-226-9996	2	22	2990-00-970-7553	1	18
5365-00-226-9996	3	22	2990-00-970-7553	2	20
2990-00-235-1709	1	24	2990-00-970-7553	3	20
2990-00-235-1709	2	26	4730-01-007-5232	2	32
2990-00-235-1709	3	26	5307-01-008-6182	1	27
4030-00-270-5436	2	47	5307-01-008-6182	2	36
4030-00-270-5436	3	47	5307-01-008-6182	3	36
4730-00-277-6352	2	41	2950-01-053-7200	1	6
4730-00-277-6352	3	41	2950-01-053-7200	2	8
5340-00-290-4520	1	28	5330-01-059-0096	1	31
5340-00-290-4520	2	35	5330-01-059-0096	2	54
5340-00-290-4520	3	35	5300-01-059-0096	3	54
5330-00-297-6468	2	42	5305-01-145-8286	2	43
5330-00-297-6468	3	42	5305-01-145-8286	3	43
5310-00-298-2747	1	40	5305-01-145-8287	2	45
5310-00-298-2747	2	63	5305-01-145-8287	3	45
5310-00-298-2747	3	63	5340-01-145-8291	2	38
2950-00-397-3363	1	9	5340-01-145-8291	3	38
2950-00-397-3363	2	11	4030-01-145-8293	2	46
3120-00-413-9604	1	14	4030-01-145-8293	3	46
3120-00-413-9604	2	16	4460-01-145-8299	2	39
3120-00-413-9604	3	16	4460-01-145-8299	3	39
4310-00-423-3892	1	22	5340-01-145-8310	2	49
4730-00-431-9307	2	33	5340-01-145-8310	3	49
4730-00-431-9307	3	34	5310-01-151-2732	1	13
4710-00-432-0055	1	30	5310-01-151-2732	2	15
4710-00-432-0055	2	53	5310-01-151-2732	3	15
4710-00-432-0055	3	53	2990-01-152-2373	1	KIT
4310-00-432-3892	2	24	2990-01-152-2373	2	KIT
5330-00-486-0417	1	2	2990-01-152-2373	3	KIT
5330-00-486-0417	2	2	4010-01-157-1343	2	48
5330-00-486-0417	3	2	4010-01-157-1343	3	48
5307-00-492-3217	1	12	2990-01-292-8579	1	3
5307-00-492-3217	2	14	2990-01-292-8579	2	3
5307-00-492-3217	3	14	2990-01-292-8579	3	3
5305-00-500-0435	1	29	5340-01-300-0409	2	56
5305-00-500-0435	2	52	5340-01-300-0409	3	56
5305-00-500-0435	3	52	5310-01-433-8977	3	25
5305-00-576-5417	1	4	2815-01-434-5208	3	10
5305-00-576-5417	2	6	2930-01-434-5503	3	24
5305-00-576-5417	3	6	2990-01-437-1570	3	8
5305-00-576-7256	2	29	2990-01-437-8266	3	8

PART NUMBER CROSS REFERENCE TO FIGURE AND ITEM NUMBER

PART NUMBER	CAGE	FIGURE NO	ITEM NO	PART NUMBER	CAGE	FIGURE NO	ITEM NO
12275840	19207	2	39	146827	53591	1	37
12275840	19207	3	39	146827	53591	2	60
12275841	19207	2	48	146827	53591	3	60
12275841	19207	3	48	152258	53591	1	9
12275864	19207	2	37	152258	53591	2	11
12275864	19207	3	37	157148	53591	1	26
12275866-1	19207	2	43	157149	53591	2	24
12275866-1	19207	3	43	157229	53591	1	25
12275866-2	19207	2	45	C157415	53591	1	12
12275866-2	19207	3	45	C157415	53591	2	14
12275867	19207	2	46	C157415	53591	3	14
12275867	19207	3	46	157482	53591	1	41
12275868	19207	2	38	157542	53591	1	32
12275868	19207	3	38	157542	53591	2	55
12275869	19207	2	49	157571	53591	1	3
12275869	19207	3	49	157571	53591	2	3
12275894	19207	1	13	157571	53591	3	3
125647	53591	3	62	157572	53591	1	33
129309	53591	1	42	157572	53591	2	56
132575	53591	1	29	157572	53591	3	56
132575	53591	2	52	157599	53591	1	30
132575	53591	3	52	157599	53591	2	53
135619	53591	1	15	157599	53591	3	53
135619	53591	2	17	157615	53591	1	6
135619	53591	3	17	157615	53591	2	8
135796	53591	1	18	157617	53591	1	5
135796	53591	2	20	157617	53591	2	7
135796	53591	3	20	157617	53591	3	7
137016	53591	1	36	157617	53591	1	27
137016	53591	2	59	C157631	53591	2	36
137016	53591	3	59	C157631	53591	3	36
137856	53591	1	17	C157631	53591	1	11
137856	53591	2	19	157809	53591	1	11
137856	53591	3	19	157809	53591	2	13
137945	53591	1	35	158567	53591	1	38
137945	53591	2	58	158567	53591	2	61
137945	53591	3	58	158567	53591	3	61
138201	53591	1	2	158568	53591	1	7
138201	53591	2	2	158568	53591	2	9
138201	53591	3	2	158568	53591	3	9
139052	53591	1	20	158581	53591	1	10
140029	53591	1	14	158581	53591	2	12
140029	53591	2	16	168982	53591	3	55
140029	53591	3	16	182349	53591	3	8
140153	53591	1	24	183234	53591	1	1
140153	53591	2	26	184054	53591	1	31
140153	16764	3	26	184054	53591	2	54
140319	16764	1	4	184054	53591	3	54
142114	16764	1	8	184907	53591	2	28
142114	16764	2	10	184910	53591	2	27
142114	16764	3	10	186752	53591	2	5
146164	16764	1	23	186752	53591	3	5
146164	16764	2	25	189814	53591	1	19
				189814	53591	2	21
				189814	53591	3	21
				191634	53591	1	22
				191634	53591	3	24
				191635	53591	3	28
				191695	53591	3	27

PART NUMBER CROSS REFERENCE TO FIGURE AND ITEM NUMBER

PART NUMBER	CAGE	FIGURE NO	ITEM NO	PART NUMBER	CAGE	FIGURE NO	ITEM NO
191804	53591	3	11	MS51525A4	96906	3	30
192766	53591	3	13	MS51525A5	96906	2	33
193801	53591	3	8	MS87006- 3	96906	2	47
193898	53591	2	4	MS87006- 3	96906	3	47
193898	53591	3	4	MS9068- 013	96906	2	40
194118	53591	3	25	MS9068- 013	96906	3	40
194671	53591	3	12	MS9068- 038	96906	2	50
2S1185	53591	1	16	MS9068- 038	96906	3	50
2S1185	11083	2	18	MS90687- 018	96906	2	51
2S1185	11083	3	18	MS90687- 018	96906	3	51
375SB16P1	89619	1	21	MS9320- 11	96906	2	44
375SB16P1	89619	2	23	MS9320- 11	96906	3	44
375SB16P1	89619	3	23	SPL51712- 6	96906	2	15
375SB16P2	89619	1	21	SPL51712- 6	96906	3	15
375SB16P2	89619	2	23				
375SB16P2	89619	3	23				
5- 5 070120CA	81343	3	34				
5705073	19207	1	KIT				
5705073	19207	2	KIT				
600- 001- 5- 16	83259	2	42				
600- 001- 5- 16	83259	3	42				
701569B	64104	1	21				
701569B	64104	2	23				
701569B	64104	3	23				
7383439	19207	1	39				
7383439	19207	2	62				
E8CR131- 0160	19207	3	KIT				
MS122162	96906	2	35				
MS122162	96906	3	35				
MS16627- 1106	96906	1	34				
MS16627- 1106	96906	2	57				
MS16627- 1106	96906	3	57				
MS16631- 1350	96906	2	22				
MS16631- 1350	96906	3	22				
MS20500- 428	96906	1	40				
MS20500- 428	96906	2	63				
MS20500- 428	96906	3	63				
MS21208C5- 20	96906	1	28				
MS21209F5- 20	96906	2	29				
MS21209F5- 20	96906	3	31				
MS27769- 1	96906	2	41				
MS27769- 1	96906	3	41				
MS28778- 4	96906	2	34				
MS28778- 4	96906	3	33				
MS28778- 5	96906	2	31				
MS29561- 238	96906	2	1				
MS29561- 238	96906	3	1				
MS29778- 5	96906	3	29				
MS35307- 360	96906	2	6				
MS35307- 360	96906	3	6				
MS39086- 101	96906	2	30				
MS39086- 101	96906	3	32				
MS51525A4	96906	2	32				

END OF WORK PACKAGE

EXPENDABLE AND DURABLE ITEMS LIST

0016 00

THIS WORK PACKAGE COVERS:

Scope, Explanation of Columns, and Expendable Supplies and Durable Items List

SCOPE

This work package lists the expendable supplies and materials you will need to operate and maintain the starter. This list is for information only and is not authority to requisition the listed items. These items are authorized to you by CTA 50-970, Expendable/Durable Items (except Medical, Class V, Repair Parts, and Heraldic Items), or CTA 8-100, Army Medical Department Expendable/Durable Items.

EXPLANATION OF COLUMNS

Column (1) – Item Number. This number is assigned to the entry in the list and is referenced in the narrative instructions to identify the item (e.g. “Use lubricating oil (Item 2, WP 0016 00).”).

Column (2) – Level. This column identifies the lowest level of maintenance that requires the listed item (F = Direct Support/AVIM, H = General Support).

Column (3) – National Stock Number (NSN). This is the NSN assigned to the item which you can use to requisition it.

Column (4) – Item Name, Description, Commercial and Government Entity Code (CAGEC), and Part Number (P/N). This column provides the other information you need to identify the item.

Column (5) – Unit of Measure (U/M). This code shows the physical measurement or count of an item as issued per the National Stock Number shown in column (3).

EXPENDABLE SUPPLIES AND DURABLE ITEMS LIST

Table 1. Expendable Supplies and Durable Items List

(1) ITEM NUMBER	(2) LEVEL	(3) NATIONAL STOCK NUMBER	(4) ITEM NAME, DESCRIPTION, CAGEC, PART NUMBER	(5) U/M
1		7920-00-205-1711	Rag, Wiping, Cotton, White: 50 lb bale (80244) 7920-00-205-1711	LB
2		9150-00-231-6689	Lubricating Oil: General Purpose (81349) MIL-PRF-32033, 1 Quart Can	QT
3		6850-00-281-1985	Dry-cleaning Solvent: 1 Gallon Can (81348) P-D-680, Type II	GL
4		7510-00-852-8179	Tape, Adhesive: Type II, 36 Yard Roll, 1 Inch Wide (81349) MIL-T-22085	RL
5		7920-00-205-2401	Brush, Cleaning, Tool and Parts (80204) 7920-00-205-2401	EA
6		4240-00-816-3819	Goggles: Industrial (80204) ANSI Z87.1	EA
7		8415-00-266-8677	Gloves: Rubber, Industrial (81349) MIL-DTL-32066	PR
8		1560-01-077-3383	Scraper, Plastic (76301) TD5030C-1E	EA
9		9150-00-231-6689	Lubricating Oil, Gen, V-V-L-800 (81348)	QT
10		8135-00-753-4662	Barrier Material, Greaseproofed-Waterproofed, Flexible, MIL-B-121, Type II, Grade A, Class II, 100 yards	RL
11		8135-00-753-4657	Paperboard, Wrapping and Cushioning	SH
12		7510-01-031-3129	Tape, Pressure Sensitive Adhesive, PPP-T-42 (81348)	RL

EXPENDABLE AND DURABLE ITEMS LIST - CONTINUED

0016 00

Table 1. Expendable Supplies and Durable Items List - Continued

(1) ITEM NUMBER	(2) LEVEL	(3) NATIONAL STOCK NUMBER	(4) ITEM NAME, DESCRIPTION, CAGEC, PART NUMBER	(5) U/M
13		7510-00-079-7905	Tape, Pressure Sensitive Adhesive, PPP-T-60 (81348)	RL
14		8105-01-235-9831	Sleeve, Interior Packaging, 1 Type, E Class, 1 Style	SL

END OF WORK PACKAGE

TOOL IDENTIFICATION LIST

THIS WORK PACKAGE COVERS:

Scope, Explanation of Columns, and Tool Identification List

SCOPE

This work package lists all common tools and supplements and special tools/fixtures needed to maintain the turbocharger.

EXPLANATION OF COLUMNS

Column (1) – Item number. This number is assigned to the entry in the list and is referenced in the initial setup to identify the item (e.g. “Magnifier (Item 3, WP 0017 00)”).

Column (2) – Item Name. This column lists the item by noun nomenclature and other descriptive features (e.g., “Gage Stock Set”).

Column (3) – National Stock Number. This is the National Stock Number (NSN) assigned to the item; use it to requisition the item.

Column (4) – Part Number/CAGEC. Indicates the primary number used by the manufacturer (individual, company, firm, corporation, or Government activity) which controls the design and characteristics of the item by means of its engineering drawings, specifications, standards, and inspections requirements to identify an item or range of items. The manufacturer’s Commercial and Government Entity Code (CAGEC) is also included.

Column (5) – Reference. This column identifies the authorizing supply catalog or RPSTL for items listed in this work package.

TOOL IDENTIFICATION LIST

Table 1. Tool Identification List

(1) ITEM NO.	(2) ITEM NAME	(3) NATIONAL STOCK NUMBER	(4) PART NUMBER/CAGEC	(5) REFERENCE
1	General Mechanic’s Tool Kit	5180-00-177-7033	SC 5180-90-CL-N26 (50980)	SC 5180-90-N26
2	Metal Scriber	5120-00-224-9728	83 (73792)	
3	Magnifier	6650-00-252-6250	GGM95 (81348)	
4	Caliper, Micrometer, Outside, 0-1.00 inch	5210-00-540-2973	T230RL (57163)	
5	Caliper, Micrometer, Outside, 3.00-4.00 inches	5210-00-221-1934	T436RL-4 (57163)	
6	Caliper, Micrometer, Outside, 1.00-2.00 inches	5210-00-243-2933	T436RL-2 (57163)	
7	Telescope Gage Set	5120-00-473-9350		
8	Socket, Socket Wrench, 5/8 Inch Deep Well	5120-00-235-5898	B107.1 (05047)	
9	Socket, Socket Wrench, 9/16 Inch Deep Well	5120-00-243-7348	B107.1 (05047)	
10	Gage Stock Set, Thickness	5120-00-267-3095	3095 (2B952)	
11	Crowfoot Attachment, Socket Wrench	5120-00-184-8397	GGG-C-1507 (81348)	

END OF WORK PACKAGE

ALPHABETICAL INDEX

Subject	Page Number	Subject	Page Number
A			
Alphabetical Index	INDEX-1	Repair	0010 00-2
Assembly	0011 00-1	Compressor Cover Adapters	
B			
Backplate		Cleaning	0008 00-1
Cleaning	0008 00-1	Inspection	0009 00-7
Inspection	0009 00-5	Installation	0011 00-14
Installation	0011 00-4	Removal	0007 00-12
Removal	0007 00-8	Compressor Wheel	
Bearing Housing		Cleaning	0008 00-1
Cleaning	0008 00-1	Inspection	0009 00-2
Inspection	0009 00-4	Installation	0011 00-7
Removal	0007 00-8	Removal	0007 00-4
Chain		Conversions	0005 00-1
Installation	0011 00-16	Corrective Action (Troubleshooting)	0004 00-2
Removal	0007 00-11	D	
Chain "S" Hook		Data	0002 00-6
Installation	0011 00-16	Description of Equipment	0002 00-1
Removal	0007 00-11	Difference Between Models	0002 00-4
Clamp		Difference Between Right and Left Hand Mounting	0002 00-4
Cleaning	0008 00-1	Disassembly of the Turbo Into Component Parts	0007 00-1
Inspection	0009 00-6	Dust Detector Cover	
Installation	0011 00-12	Cleaning	0008 00-1
Removal	0007 00-3	Inspection	0009 00-7
Cleaning of Component Parts	0008 00-1	Installation	0011 00-15
Cleaning the Turbo Before Disassembly	0006 00-1	Removal	0007 00-11
Common Tools and Equipment	0003 00-1	E	
Compressor Cover		End Play	0004 00-2
Cleaning	0008 00-1	Equipment Data	0002 00-6
Inspection	0009 00-2	Equipment Description and Data	0002 00-1
Installation	0011 00-9	Equipment Identification	0001 00-1
Removal	0007 00-3	Equipment Improvement Recommendations (EIRs)	0001 00-1
		Expendable Supplies and Durable Items List	0015 00-1

ALPHABETICAL INDEX - Continued

Subject	Page Number	Subject	Page Number
F		M	
Filter		Maintenance Forms and Records	0001 00-1
Installation	0011 00-14	Maintenance Procedures, General	0005 00-1
Removal	0007 00-12	Manufactured Items	0003 00-1
Filter Retaining Strap		Metal Seal Rings	
Cleaning	0008 00-1	Installation	0011 00-6
Inspection	0009 00-7	Removal	0007 00-6
Installation	0011 00-15	Mounting Legs	
Removal	0007 00-12	Cleaning	0008 00-1
Flinger Sleeve		Inspection	0009 00-6
Installation	0011 00-2	Installation	0011 00-13
Removal	0007 00-6	Removal	0007 00-1
Flinger Sleeve Insert		N	
Installation	0011 00-7	National Stock Number and Part Number Indexes	0014 00-19
Removal	0007 00-5	Nomenclature Cross Reference List	0001 00-1
G		O	
General Maintenance Instructions	0005 00-1	Oil Deflector	
H		Cleaning	0008 00-1
How To Use This Manual	iii	Inspection	0009 00-4
How Your Turbo Works	0002 00-1	Installation	0011 00-6
I		Removal	0007 00-6
Identification Plate	0002 00-6	Oil Drain Tube	
Illustrations	0005 00-1	Cleaning	0008 00-1
Improvised Tools	0003 00-1	Inspection	0009 00-6
Inlet Adapters (See Compressor Cover Adapters)		Installation	0011 00-13
Insert (See Flinger Sleeve Insert)		Removal	0007 00-1
Inspection	0004 00-1	Repair	0010 00-3
Inspection of Component Parts	0009 00-1	Outlet Adapters (See Compressor Cover Adapters)	
L		Operational Testing	0011 00-16
Long Term Storage	0012 00-1	P	
Lower Sleeve Bearing (See Sleeve Bearings)		Packing with Retainer	
Lower Thrust Ring (See Thrust Rings)		Installation	0011 00-16
Lubrication	0002 00-2	Removal	0007 00-11

ALPHABETICAL INDEX - Continued

Subject	Page Number	Subject	Page Number
Preformed Packings		Spacer	
Installation	0011 00-6	Installation	0011 00-5
Removal	0007 00-12	Removal	0007 00-7
Preparation for Storage of Equipment	0001 00-1	Special Tools	0003 00-1
Preservation	0012 00-1	Special Tools List	0014 00-18
Publication Indexes	0013 00-2	Storage	0012 00-1
Purpose of Equipment	0001 00-1	Supply Catalogs	0013 00-2
R		T	
Radial Movement	0004 00-1	Technical and Reference Documents	0013 00-1
References	0013 00-1	Thrust Bearing	
Repair of Component Parts	0010 00-1	Installation	0011 00-5
Repair Parts	0003 00-1	Removal	0007 00-7
Repair Parts and Special Tools List (RPSTL)	0014 00-1	Thrust Rings	
Reporting Errors and Recommending Improvements	i	Installation	0011 00-5
Retaining Rings		Removal	0007 00-7
Installation	0011 00-3	Thrust Sleeve Bearing	
Removal	0007 00-9	Installation	0011 00-5
S		Removal	0007 00-7
Scope of the Manual	0001 00-1	Thrust Washer Bearing	
Shield, Turbocharger		Installation	0011 00-3
Cleaning	0008 00-1	Removal	0007 00-9
Inspection	0009 00-7	Tool Identification List	0016 00-1
Installation	0011 00-9	Troubleshooting Guide	0004 00-3
Removal	0007 00-8	Troubleshooting Instructions	0004 00-1
Repair	0010 00-3	Turbine Backplate (See Backplate)	
Shims		Turbine Housing	
Installation	0011 00-7	Cleaning	0008 00-1
Removal	0007 00-5	Inspection	0009 00-5
Short Term Storage	0012 00-1	Installation	0011 00-4
Sleeve Bearings,		Removal	0007 00-8
Installation	0011 00-3	Turbine Wheel and Shaft Assembly	
Removal	0007 00-9	Cleaning	0008 00-1
Source, Maintenance, and Recoverability (SMR) Codes	0014 00-1	Inspection	0009 00-3
		Installation	0011 00-4
		Removal	0007 00-8

ALPHABETICAL INDEX - Continued

Subject	Page Number	Subject	Page Number
U		V	
Upper Sleeve Bearing (See Sleeve Bearings)		Visual Checks	0004 00-1
Upper Thrust Ring (See Thrust Rings)			

By Order of the Secretary of the Army:

PETER J. SCHOOMAKER
*General, United States
Army
Chief of Staff*

Official:

SANDRA R. RILEY
*Administrative Assistant to the
Secretary of the Army*
0526314

DISTRIBUTION: To be distributed in accordance with the Initial Distribution Number (IDN) 380721 requirements for TM 9-2990-205-34&P.

RECOMMENDED CHANGES TO PUBLICATIONS AND BLANK FORMS For use of this form, see AR 25-30; the proponent agency is ODISC4.					Use Part II (reverse) for Repair Parts and Special Tools Lists (RPSTL) and Supply Catalogs/Supply Manuals (SC/SM).		Date
TO: (Forward to proponent of publication or form) (Include ZIP Code)					FROM: (Activity and location) (include ZIP code)		
PART I – ALL PUBLICATIONS (EXCEPT RPSTL AND SC/SM) AND BLANK FORMS							
PUBLICATION/FORM NUMBER TM 9-2990-205-34&P				DATE 30 September 2005		TITLE Direct Support and General Support Maintenance Manual for Turbosupercharger Model 5HDR (including Repair Parts and Special Tools List)	
ITEM	PAGE	PARA	LINE	FIGURE NO.	TABLE	RECOMMENDED CHANGES AND REASON	
	3-1	3-2				Change part no. 12366708-1 to 655595-3	
*Reference to line numbers within the paragraph or subparagraph.							
TYPED NAME, GRADE OR TITLE				TELEPHONE EXCHANGE/AUTOVON, PLUS EXTENSION		SIGNATURE	

TO: (Forward direct to addressee listed in publication)	FROM: (Activity and location) (Include Zip Code)	DATE
---	--	------

PART II - REPAIR PARTS AND SPECIAL TOOL LISTS AND SUPPLY CATALOGS/SUPPLY MANUALS

PUBLICATION NUMBER TM 9-2990-205-34&P	DATE 30 September 2005	TITLE Direct Support and General Support Maintenance Manual for Turbosupercharger Model 5HDR (including Repair Parts and Special Tools List)
--	---------------------------	---

PAGE NO.	COLM NO.	LINE NO.	NATIONAL STOCK NUMBER	REFERENCE NO.	FIGURE NO.	ITEM NO.	TOTAL NO. OF MAJOR ITEMS SUPPORTED	RECOMMENDED ACTION
B-7	6		2950-00-118-8535			16		Nomenclature should read "Bearing, Washer, Thrust"

PART III - REMARKS (Any general remarks or recommendations, or suggestions for improvement of publications and blank forms. Additional blank sheets may be used if more space is needed.)

TYPED NAME, GRADE OR TITLE	TELEPHONE EXCHANGE/AUTOVON, PLUS EXTENSION	SIGNATURE
----------------------------	--	-----------

RECOMMENDED CHANGES TO PUBLICATIONS AND BLANK FORMS For use of this form, see AR 25-30; the proponent agency is ODISC4.	Use Part II (reverse) for Repair Parts and Special Tools Lists (RPSTL) and Supply Catalogs/Supply Manuals (SC/SM).	Date
---	--	------

TO: (Forward to proponent of publication or form) (Include ZIP Code)	FROM: (Activity and location) (include ZIP code)
---	---

PART I – ALL PUBLICATIONS (EXCEPT RPSTL AND SC/SM) AND BLANK FORMS

PUBLICATION/FORM NUMBER TM 9-2990-205-34&P	DATE 30 September 2005	TITLE Direct Support and General Support Maintenance Manual for Turbosupercharger Model 5HDR (including Repair Parts and Special Tools List)
---	---------------------------	--

ITEM	PAGE	PARA	LINE	FIGURE NO.	TABLE	RECOMMENDED CHANGES AND REASON

**Reference to line numbers within the paragraph or subparagraph.*

TYPED, GRADE OR TITLE	TELEPHONE EXCHANGE/AUTOVON, PLUS EXTENSION	SIGNATURE
-----------------------	--	-----------

TO: <i>(Forward direct to addressee listed in publication)</i>	FROM: <i>(Activity and location) (Include Zip Code)</i>	DATE
--	---	------

PART II - REPAIR PARTS AND SPECIAL TOOL LISTS AND SUPPLY CATALOGS/SUPPLY MANUALS

PUBLICATION NUMBER TM 9-2990-205-34&P	DATE 30 September 2005	TITLE Direct Support and General Support Maintenance Manual for Turbosupercharger Model 5HDR (including Repair Parts and Special Tools List)
--	---------------------------	--

PAGE NO.	COLM NO.	LINE NO.	NATIONAL STOCK NUMBER	REFERENCE NO.	FIGURE NO.	ITEM NO.	TOTAL NO. OF MAJOR ITEMS SUPPORTED	RECOMMENDED ACTION

PART III - REMARKS *(Any general remarks or recommendations, or suggestions for improvement of publications and blank forms. Additional blank sheets may be used if more space is needed.)*

TYPED NAME, GRADE OR TITLE	TELEPHONE EXCHANGE/AUTOVON, PLUS EXTENSION	SIGNATURE
----------------------------	--	-----------

RECOMMENDED CHANGES TO PUBLICATIONS AND BLANK FORMS For use of this form, see AR 25-30; the proponent agency is ODISC4.	Use Part II (reverse) for Repair Parts and Special Tools Lists (RPSTL) and Supply Catalogs/Supply Manuals (SC/SM).	Date
---	--	------

TO: (Forward to proponent of publication or form) (Include ZIP Code)	FROM: (Activity and location) (include ZIP code)
---	---

PART I – ALL PUBLICATIONS (EXCEPT RPSTL AND SC/SM) AND BLANK FORMS

PUBLICATION/FORM NUMBER TM 9-2990-205-34&P	DATE 30 September 2005	TITLE Direct Support and General Support Maintenance Manual for Turbosupercharger Model 5HDR (including Repair Parts and Special Tools List)
---	---------------------------	--

ITEM	PAGE	PARA	LINE	FIGURE NO.	TABLE	RECOMMENDED CHANGES AND REASON

**Reference to line numbers within the paragraph or subparagraph.*

TYPED, GRADE OR TITLE	TELEPHONE EXCHANGE/AUTOVON, PLUS EXTENSION	SIGNATURE
-----------------------	--	-----------

TO: <i>(Forward direct to addressee listed in publication)</i>	FROM: <i>(Activity and location) (Include Zip Code)</i>	DATE
--	---	------

PART II - REPAIR PARTS AND SPECIAL TOOL LISTS AND SUPPLY CATALOGS/SUPPLY MANUALS

PUBLICATION NUMBER TM 9-2990-205-34&P	DATE 30 September 2005	TITLE Direct Support and General Support Maintenance Manual for Turbosupercharger Model 5HDR (including Repair Parts and Special Tools List)
--	---------------------------	--

PAGE NO.	COLM NO.	LINE NO.	NATIONAL STOCK NUMBER	REFERENCE NO.	FIGURE NO.	ITEM NO.	TOTAL NO. OF MAJOR ITEMS SUPPORTED	RECOMMENDED ACTION

PART III - REMARKS *(Any general remarks or recommendations, or suggestions for improvement of publications and blank forms. Additional blank sheets may be used if more space is needed.)*

TYPED NAME, GRADE OR TITLE	TELEPHONE EXCHANGE/AUTOVON, PLUS EXTENSION	SIGNATURE
----------------------------	--	-----------

RECOMMENDED CHANGES TO PUBLICATIONS AND BLANK FORMS For use of this form, see AR 25-30; the proponent agency is ODISC4.	Use Part II (reverse) for Repair Parts and Special Tools Lists (RPSTL) and Supply Catalogs/Supply Manuals (SC/SM).	Date
---	--	------

TO: (Forward to proponent of publication or form) (Include ZIP Code)	FROM: (Activity and location) (include ZIP code)
---	---

PART I – ALL PUBLICATIONS (EXCEPT RPSTL AND SC/SM) AND BLANK FORMS

PUBLICATION/FORM NUMBER TM 9-2990-205-34&P	DATE 30 September 2005	TITLE Direct Support and General Support Maintenance Manual for Turbosupercharger Model 5HDR (including Repair Parts and Special Tools List)
---	---------------------------	--

ITEM	PAGE	PARA	LINE	FIGURE NO.	TABLE	RECOMMENDED CHANGES AND REASON

**Reference to line numbers within the paragraph or subparagraph.*

TYPED, GRADE OR TITLE	TELEPHONE EXCHANGE/AUTOVON, PLUS EXTENSION	SIGNATURE
-----------------------	--	-----------

TO: <i>(Forward direct to addressee listed in publication)</i>	FROM: <i>(Activity and location) (Include Zip Code)</i>	DATE
--	---	------

PART II - REPAIR PARTS AND SPECIAL TOOL LISTS AND SUPPLY CATALOGS/SUPPLY MANUALS

PUBLICATION NUMBER TM 9-2990-205-34&P	DATE 30 September 2005	TITLE Direct Support and General Support Maintenance Manual for Turbosupercharger Model 5HDR (including Repair Parts and Special Tools List)
--	---------------------------	--

PAGE NO.	COLM NO.	LINE NO.	NATIONAL STOCK NUMBER	REFERENCE NO.	FIGURE NO.	ITEM NO.	TOTAL NO. OF MAJOR ITEMS SUPPORTED	RECOMMENDED ACTION

PART III - REMARKS *(Any general remarks or recommendations, or suggestions for improvement of publications and blank forms. Additional blank sheets may be used if more space is needed.)*

TYPED NAME, GRADE OR TITLE	TELEPHONE EXCHANGE/AUTOVON, PLUS EXTENSION	SIGNATURE
----------------------------	--	-----------

CONVERSION TABLE

inch	decimal	mm	inch	decimal	mm	inch	decimal	mm
1/64	0.015625	0.3969	23/64	0.359375	9.1281			
1/32	0.031250	0.7938	3/8	0.375000	9.5250	45/64	0.703125	17.8594
3/64	0.046875	1.1906				23/32	0.718750	18.2562
1/16	0.062500	1.5875	25/64	0.390625	9.9219	47/64	0.734375	18.6531
			13/32	0.406250	10.3188	3/4	0.750000	19.050
5/64	0.078125	1.9844	27/64	0.421875	10.7156			
3/32	0.093750	2.3812	7/16	0.437500	11.1125	49/64	0.765625	19.4469
7/64	0.109375	2.7781				25/32	0.781250	19.8437
1/8	0.125000	3.1750	29/64	0.453125	11.5094	51/64	0.796875	20.2406
			15/32	0.468750	11.9062	13/16	0.812500	20.6375
9/64	0.140625	3.5719	31/64	0.484375	12.3031			
5/32	0.156250	3.9688	1/2	0.500000	12.7000	53/64	0.828125	21.0344
11/64	0.171875	4.3656				27/32	0.843750	21.4312
3/16	0.187500	4.7625	33/64	0.515625	13.0969	55/64	0.859375	21.8281
			17/32	0.531250	13.4938	7/8	0.875000	22.2250
13/64	0.203125	5.1594	35/64	0.546875	13.8906			
7/32	0.218750	5.5562	9/16	0.562500	14.2875	57/64	0.890625	22.6219
15/64	0.234375	5.9531				29/32	0.906250	23.0188
1/4	0.250000	6.3500	37/64	0.578125	14.6844	59/64	0.921875	23.4156
			19/32	0.593750	15.0812	15/16	0.937500	23.8125
17/64	0.265625	6.7469	39/64	0.609375	15.4781			
9/32	0.281250	7.1438	5/8	0.625000	15.8750	61/64	0.953125	24.2094
19/64	0.296875	7.5406				31/32	0.967500	24.6062
5/16	0.312500	7.9375	41/64	0.640625	16.2719	63/64	0.984375	25.0031
			21/32	0.656250	16.6688			
21/64	0.328125	8.3344	43/64	0.671875	17.0656	1	1.000000	25.4000
11/32	0.343750	8.7312	11/16	0.687500	17.4625			

THE METRIC SYSTEM AND EQUIVALENTS

LINEAR MEASURE

1 Centimeter = 10 Millimeters = 0.01 Meters = 0.3937 Inches
 1 Meter = 100 Centimeters = 1000 Millimeters = 39.37 Inches
 1 Kilometer = 1000 Meters = 0.621 Miles

WEIGHTS

1 Gram = 0.001 Kilograms = 1000 Milligrams = 0.035 Ounces
 1 Kilogram = 1000 Grams = 2.2 Lb.
 1 Metric Ton = 1000 Kilograms = 1 Megagram = 1.1 Short Tons

LIQUID MEASURE

1 Milliliter = 0.001 Liters = 0.0338 Fluid Ounces
 1 Liter = 1000 Milliliters = 33.82 Fluid Ounces

SQUARE MEASURE

1 Sq. Centimeter = 100 Sq. Millimeters = 0.155 Sq. Inches
 1 Sq. Meter = 10,000 Sq. Centimeters = 10.76 Sq. Feet
 1 Sq. Kilometer = 1,000 Sq. Meters = 0.386 Sq. Miles

CUBIC MEASURE

1 Cu. Centimeter = 1000 Cu. Millimeters = 0.06 Cu. Inches
 1 Cu. Meter = 1,000,000 Cu. Centimeters = 35.31 Cu. Feet

TEMPERATURE

$5/9 (^{\circ}\text{F} - 32) = ^{\circ}\text{C}$
 212° Fahrenheit is equivalent to 100° Celsius
 90° Fahrenheit is equivalent to 32.2° Celsius
 32° Fahrenheit is equivalent to 0° Celsius
 $(9/5 \times ^{\circ}\text{C}) + 32 = ^{\circ}\text{F}$

APPROXIMATE CONVERSION FACTORS

TO CHANGE	TO	MULTIPLY BY
Inches	Centimeters	2.540
Feet	Meters	0.305
Yards	Meters	0.914
Miles	Kilometers	1.609
Square Inches	Square Centimeters	6.451
Square Feet	Square Meters	0.093
Square Yards	Square Meters	0.836
Square Miles	Square Kilometers	2.590
Acres	Square Hectometers	0.405
Cubic Feet	Cubic Meters	0.028
Cubic Yards	Cubic Meters	0.765
Fluid Ounces	Millimeters	29.573
Pints	Liters	0.473
Quarts	Liters	0.946
Gallons	Liters	3.785
Ounces	Grams	28.349
Pounds	Kilograms	0.454
Short Tons	Metric Tons	0.907
Pound-Feet	Newton-Meters	1.356
Pounds per Square Inch	Kilopascals	6.895
Miles per Gallon	Kilometers per Liter	0.425
Miles per Hour	Kilometers per Hour	1.609

TO CHANGE	TO	MULTIPLY BY
Centimeters	Inches	0.394
Meters	Feet	3.280
Meters	Yards	1.094
Kilometers	Miles	0.621
Square Centimeters	Square Inches	0.155
Square Meters	Square Feet	10.764
Square Meters	Square Yards	1.196
Square Kilometers	Square Miles	0.386
Square Hectometers	Acres	2.471
Cubic Meters	Cubic Feet	35.315
Cubic Meters	Cubic Yards	1.308
Milliliters	Fluid Ounces	0.034
Liters	Pints	2.113
Liters	Quarts	1.057
Liters	Gallons	0.264
Grams	Ounces	0.035
Kilograms	Pounds	2.205
Metric Tons	Short Tons	1.102
Newton-Meters	Pound-Feet	0.738
Kilopascals	Pounds per Square Inch	0.145
Kilometers per Liter	Miles per Gallon	2.354
Kilometers per Hour	Miles per Hour	0.621

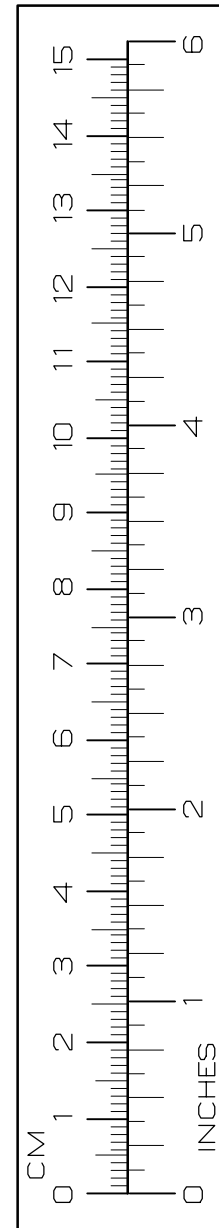

PIN: 018452-000